

# Radio Frequency Identification Technology in Libraries

Ali Alwadi<sup>1</sup>, Jeff Kilby<sup>2</sup>, Amjad Gawanmeh<sup>3</sup>, Hakilo Sabit<sup>4</sup>

<sup>1,2,4</sup>School of Engineering, Auckland University of Technology, Auckland NZ

Email: {nsj6117, jkilby,hsabit}@autuni.ac.nz

<sup>3</sup>Department of Electrical and Computer Engineering, Khalifa University, UAE

Email: amjad.gawanmeh@kustar.ac.ae

**Abstract**— This paper is a baseline document to review the latest technologies, algorithms and available hardware that can be used to build and automate a library system using Radio Frequency Identification technology as the infrastructure, allowing the librarian to track and manage real-life objects. The purpose is to review the current research that have been accomplished around this area in order to produce the best possible design, and implementation of a robust solution with maximum efficiency to automate a library system. The article first provides an overview of the radio frequency identification technology, its history, radio frequency principle, and how distance and frequency can affect the signal coverage distance. Then radio frequency identification structure and types are explained, after that the paper evaluates the latest researches in the radio frequency identification infrastructure and middleware. Finally the issue of radio signal collision is discussed, and corresponding anti-collision algorithms are briefly explained.

**Keywords**— Active Passive RFID, Far Field, Near Field, RFID in libraries.

## I. INTRODUCTION

Radio Frequency Identification (RFID) is the most widely used communication protocol that serves the Internet of Things concept today [2-3], by connecting the real-life objects via an RFID network. Radio Frequency (RF) is simply a signal for transferring data between RFID senders and receivers.

RFID is a wireless communication technology that uses the RF signal to transfer data between the RFID sender and receiver. The sender in a library RFID system is the RFID Reader, and the Receiver is the RFID Tag. In an RFID system, normally RFID Tags are attached to objects, and there should be an RFID reader connected to the same system, which should “sense” the information stored in the RFID Tag [2-3]. A simplified diagram for a conventional RFID system is shown in Fig. 1.

The wide use of this technology in automating the industrial, educational, and even home processes have made it very common and widely known as a standard for warehouse tracking applications.

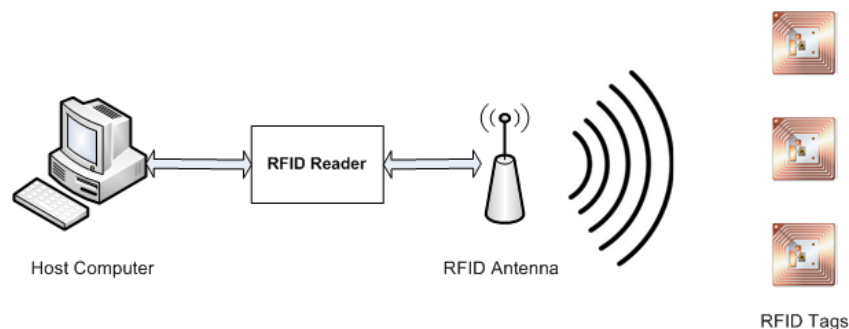

**FIGURE 1: CONVENTIONAL RFID SYSTEM**

The reason behind this may be attributed to two main factors: (a) The first factor is the dramatic decrease of the market price for the RFID Tags. (b) The second factor is the increasing demand on this technology from institutions in both private and public sectors [4].

In an RFID-based library system, library objects are expected to become active participants in library system, and the management processes. As they are able to interact and communicate among themselves and the environment by exchanging data and information ‘sensed’ about the environment; While reacting autonomously to the ‘real/physical world’ events, and influencing it by running processes that trigger actions and create services with or without direct human intervention. Interfaces in the form of services facilitate interactions with these ‘smart objects’ over the library network, query and change

their state and any information associated with them, taking into account security and privacy issues associated with the query process [5-6].

Using the service interfaces, services will be able to interact with these “smart things/objects” which will provide the necessary link via the network, to query, change their state, and retrieve any information associated with them. There are security and privacy concerns around these processes; which can be solved by:

1. Introducing anti-collision algorithms.
2. Applying the ISO standard on the middleware and tag information specifications.

Based on the tag specifications, RFID Tags can be divided into two main categories; Passive RFID, and active RFID Tags [4].

All tags contain an integrated circuit that stores the tag information [4]. Passive tags do not have an internal power source to power up the tag, they depend on the power of the radio frequency signal transmitted from the reader antenna. Active tags are called active for one simple reason; they have an internal power source, which is normally a small battery that provides the integrated circuit with the required power. The advantages of active tags are: (a) better reading distance, (b) greater memory capacity, (c) they are programmable which enables the system administrator to reprogram the tag whenever necessary [4][7-8].

RFID has been used widely in numerous industries, such as logistics, supply chain management, and quick warehouse management systems. RFID can be used to identify and track location of shipping containers and items in warehouses, which enables the system administrator to track items during shipping, warehousing, or shelving [9]. In addition, RFID has several ubiquitous applications, including inventory management [9], transportation and logistics [10], object identification and tracking [11], authentication and security [11-15]. Due to the recent amount of research and applications conducted on RFID, an up-to-date state of the art review on the subject is proposed. The paper is a review that covers RFID systems used in libraries, and it is organized as follows:

- Section I - RFID principles and categories.
- Section II - Summary of near-field and far-field.
- Section III - System architecture.
- Section IV - Security constraints.
- Section V - Conclusion.

## II. RFID PRINCIPLES AND CATEGORIES

### 2.1 RFID History

In 1896, Guglielmo Marconi demonstrated the first successful transmission of radiotelegraphy across the Atlantic, which triggered the revolution in radioactive era, since then, the RFID progress was mainly for military purposes. In the 1970s, the research on RFID started to accelerate very fast, this acceleration was driven by developers, educational institutions and commercial laboratories [16]. These researches had participated heavily in improving the tag hardware, RF immittance, and tag size. The key to this advancement was the use of low-voltage, low-power CMOS logic circuit. Tag memory utilized switches or wire bonds which had improved with the use of fusible link diode arrays by the end of the decade [16].

The invention of the transistor has led the way to the current semiconductor revolution, which contributed in the development of all sectors including the digital world; RFID has got its share of this bloom. A lot of RFID concepts have arose; one of these is “Chipless RFID system”. The system contains a transmitter, receiver, and two antennas. One antenna is designated to send the RF signal, and the second to receive the tag response. [2-3][7]. Chipless RFID system solely depends on the backscattered signal from the tag for identification and localization unlike conventional RFID system, which rely mostly on the processing capabilities of the tag’s integrated circuit [2]. Localization methods for conventional chipped tags rely mostly on the processing capabilities of the integrated circuit [2].

Localization techniques for Chipped RFID tags can be divided into three categories:

- Round-trip time-of-flight (RTOF): The reader estimates the time taken between the transmission of the interrogation wave and the received signal [2].
- Received signal strength (RSS): An indicator value calculated based on the power loss value detected by the reader antenna based on the reader-to-tag distance.
- Phase evaluation method: also called Phase Of Arrival (POA), uses the delay, expressed as a fraction of the signal's wavelength, to estimate distance [17].

The main focus of this paper is chipped RFID Localization, and more specifically the research is focusing on the Received Signal Strength technique to identify and track library objects.

## 2.2 RFID Principle

With the mass production and falling cost of tags, passive UHF RFID is becoming a widespread method of inventory tracking and item identification. Before going further on this subject; a new technical term needs to be explained; Load Modulation -which is how RFID system transfers data- the antenna uses radio frequency signal to transmit data, by modulating the amplitude of the carrier radio frequency signal to combine it with the carried signal [18].

In an RFID system, load modulation procedure using subcarrier is primarily used in inductively coupled systems for data transfer between the tag and the reader [19]. The tag's antenna is responsible of capturing the energy emitted from the reader, and also transferring the tag's modulated information that is programmed in an integrated chip. In every chip there is a reader that powers up the tag from the energy captured by the antenna. Receiver circuit is a key component of RFID reader, which is the main component that has been rapidly developed during recent years as shown in Fig. 3.) [20].

RFID systems operate in a wide range of the spectrum depending on the antenna and tag design, which can range from 100 kHz to microwave frequencies 5.8 GHz. The relying technology requires that the RFID systems must be operated in the UHF (Ultra High Frequency) frequencies occupying the ISM bands in 860 – 960 MHz according to frequency restrictions in different countries. The read range offered by UHF RFID makes this frequency the most attractive for supply chain management implementations. World-assigned RFID frequency bands range from high frequency (HF) up to microwaves [4][21-22]; The allocated band at ultra-high frequency (UHF) ranges from 860 MHz to 5.8 GHz. Table 1 categorizes the frequencies used in RFID with example uses, advantages and disadvantages of using each frequency band.

**TABLE 1**  
**RADIO FREQUENCY BANDS**

<i>RF Band</i>	<i>ADVANTAGES/ APPLICATIONS</i>	<i>Disadvantages</i>	<i>RF Range</i>
<i>Low Frequency (LF)</i>	Relatively Inexpensive Good Penetration Used in Access Control	Short read range Slow read speed	100–500 KHz
<i>High Frequency (HF)</i>	Good Penetration Medium read range Medium speed Used in Smart Cards	Expensive	10–15 MHz
<i>Ultra-High Frequency (UHF)</i>	Long Distance High Speed Used Entry Control Vehicle ID.	Expensive Requires a Line-of-Sight to read the tag	850–950 MHz
<i>Microwave (High UHF)</i>	Long Distance High Speed Used in Wifi	Expensive Bad Penetration Line-of-Sight reading	2.4–5.8 GHz

Based on the type of the RF wave used in transferring power from the reader to the tag, one type of classification divides the RFID into two main categories. The first category is Near Field (magnetic induction). The second type is Far-Field (electromagnetic (EM) wave capture).

The principle of the underlying technology is the same for both types. They both take advantage of the Electro-Magnetic characteristics associated with the RF signal to power up the tag. Both transfer enough power to remote tags to sustain their operation, its typically between 10  $\mu$ W and 1 mW, depending on the tag type. Both types describe certain electromagnetic areas formed by a Radio Frequency signal transmitted by an antenna [8].

There is a thin line between both terms, and also there is a transition area between them as well, which has the characteristics of both regions. Electromagnetically; far-field is commonly used whenever a long reading range is required, and typical UHF RFID reader antenna works with a pure far-field characteristic. Inductively near-field operation is usually used for objects surrounded by metals or liquids [23-24].

The boundary between near-field and far-field regions is inversely proportional to carrier frequency and approximately is equal to:

$$d=c/2pf \quad (1)$$

where d is the distance, c is the speed of light, and f is the frequency. Therefore, only low carrier frequencies are used in near-field coupling tags; the two most commonly used are 128 kHz (LF) and 13.56 MHz (HF) [25].

### 2.3 Near-field RFID

Near-Field is a load modulation technique that uses the coupling to transfer RF signal between the reader and the tag. It is a magnetic induction that is normally a result of a reader passes a large alternating current through the reader coil, resulting in an alternating magnetic field. If a tag is placed that incorporates a smaller coil (see Fig. 2.) in this field, an alternating voltage will appear across it. If this voltage is rectified and coupled to a capacitor, a reservoir of charge accumulates, which you can then use to power the tag chip [8][26].

The EM field in the near-field region is reactive in nature, the electric and the magnetic fields are orthogonal. Depending on the type of antenna, one field (such as the electric field for a dipole or magnetic field for a coil) dominates the other [25]. Near-Field coupling was one of the first approaches to be chosen for Passive RFID implementations around the world because of its design simplicity despite its physical limitations [8][27].

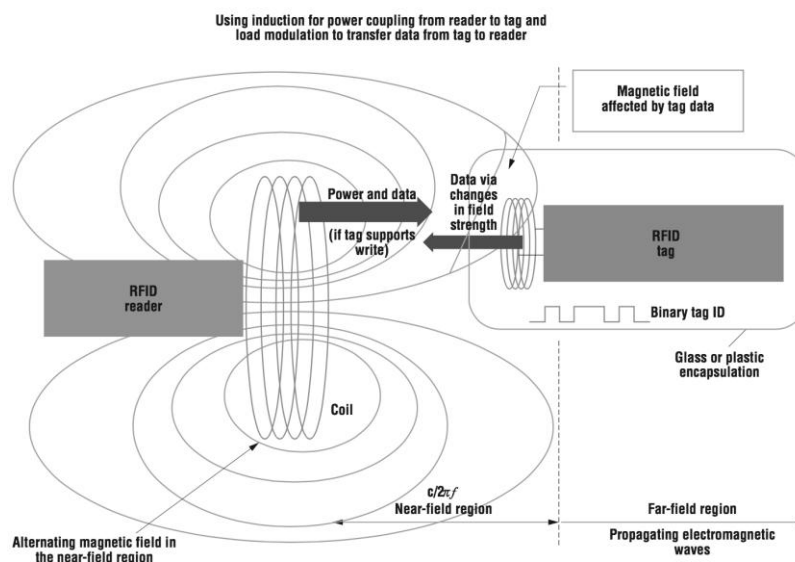

FIGURE 2: NEAR-FIELD COUPLING (WANT 2006)

The range for which we can use magnetic induction is highly dependent on the tag's frequency (See Table 2.). As the frequency of operation increases, the distance over which near-field coupling can operate decreases. A further limitation is the energy available for induction as a function of distance from the reader coil. The magnetic field drops off at a factor, which can be calculated in Eq. (2):

$$F = 1/r^3 \quad (2)$$

where  $F$  is the drop factor,  $r$  is the distance between the tag and the reader, along a centre line perpendicular to the coil's plane. So; the magnetic field drops dramatically as the distance between the tag and the reader increases. As applications require more bits stored in the IC circuit, it is also required to maintain a fixed read rate by distinguishing multi-pole tags in the same read range, the tag requires a higher data rate and thus a higher operating frequency. These design pressures have led to new passive RFID designs based on far-field communication [8]; This will be discussed in details in the next section.

As the signal range for this type of coupling is small compared to the other types of RFID techniques; which will result in designing the reader antenna with larger than normal antenna in order to enlarge the interrogation zone to cover up the short read range for the RFID Tag, for instance 150 x 150 mm<sup>2</sup> [8][27]. Moreover, the conventional solid-line loop with the perimeter comparable to one operating wavelength cannot produce even magnetic field distribution in the near-field zone of the antenna for one simple reason; the current distribution along the loop experiences phase-inversion, and the current approaches zero. The magnetic field is relatively weak in certain region of the interrogation zone, which degrades the reliability of RFID tag detection [28].

Some electrically large loop antennas have been reported to generate strong and even magnetic field. Dobkin et al. presented a segmented magnetic antenna consisting of a number of segments and each segment is composed of a metal line and a series of lumped capacitors [29]. A segmented loop antenna with a diameter of 10 cm performed a desirable performance at a frequency of 915 MHz. Oliver proposed the broken-loop antennas in 2008. Three broken-loop antennas using different coupled lines, namely triple line, double line and single line, were demonstrated in the U.S. design patents [30-32]. Finally Xianming Qing, Chean Khan Goh, and Zhi Ning Chen presented a segmented loop antenna that generates a strong and even magnetic field distribution in a large near-field zone for broadband UHF near-field RFID applications [27].

To achieve the required reading range, the antenna with the suitable design must be chosen. Choosing the right antenna depends on the designated tag size, reader antenna size, and operating frequency. The designed antenna should generate a magnetic field evenly distributed across the 3D space to cover as much passive RFID tags as possible, which conventional line loop antennas cannot achieve.

## 2.4 Far-Field RFID

Far-field system adopts electromagnetic radiation to transfer information between a reader and tags unlike Near-Field which utilizes capacitive coupling to transfer information, see Table 2.

Far-field RFID systems operate at ultra-high frequency (UHF, 840-960 MHz) or microwave frequency (2.45 GHz-24 GHz), with a long reading range compared to that for the Near-Field, Table 2. Shows the frequency bands and their categories [33].

Far-Field RFID tags capture EM waves propagating from a dipole antenna attached to the reader. A smaller dipole antenna in the tag receives this energy as an alternating potential difference that appears across the arms of the dipole. A diode can rectify this potential and link it to a capacitor, which will result in an accumulation of energy in order to power its electronics. However, unlike the inductive designs, the tags are beyond the range of the reader's near field, and information can't be transmitted back to the reader using load modulation [8].

A far-field system's range is limited by: the amount of energy that reaches the tag from the reader, and by how sensitive the reader's radio receiver is to the reflected signal. Attenuation occurs as EM waves radiate from the reader to the tag [8]. The actual returned signal is very small, as it's the result of two attenuations, each based on an inverse square law, the first attenuation occurs as EM waves radiate from the reader to the tag, and the second when reflected waves travel back from the tag to the reader. Therefore the returning energy is:

$$F = 1/r^4 \quad (3)$$

where  $r$  is the distance between the tag and the reader [8].

These days, as the size of the semiconductor-based electronics is getting lower and lower, the energy required to power up the tag continues to decrease, which serves the purpose of RFID very well. Furthermore; customized RFID Tags can be designed and manufactured at a very low cost, and they can be read from a distance that might reach up to 4-6 metres with average power consumption 100 dBm (in a frequency of 2.4 GHz. A typical far-field reader can successfully interrogate tags 3 m away, and some RFID companies claim their products have read ranges of up to 6m, refer to Table 1. [8].

## 2.5 Summary of Near Field and Far-Field

Inductive coupling technique is preferred in most near-field RFID applications mainly for one reason; Most of the reactive energy is in the Magnetic Field; any of the load modulation techniques can be used to transfer information between the tag and the antenna and vice versa [27].

The electro-magnetic field in the far-field region is radioactive in nature. Coupling here captures EM energy at a tag's antenna as a potential difference. Part of the energy incident on a tag's antenna is reflected back due to an impedance mismatch between the antenna and the load circuit. Changing the mismatch or loading on the antenna can vary depending on the amount of reflected energy, which is also called Backscattering [16]. Table 2. summarizes the characteristics and differences for both types.

**TABLE 2**  
**NEAR-FIELD VS. FAR-FIELD**

Property	Near-Field	Far-Field
Tag Read Range	$\lambda = 300/f$ MHz Between 5mm to 10 cm depending on the frequency and antenna	$\lambda = 300/f$ MHz Can reach up to 22.1 metres for some frequencies
Reader Antenna	Small, Omni-directional	Resonant, directional Small antenna size for high frequencies
Usage	Metal or liquid surrounded objects	Whenever a long reading range is required
Modulation	Load Modulation using capacitive coupling	Electromagnetic radiation
Electro Magnetic Signal	Radiative-like signal	Radiative-like signal

## III. SYSTEM ARCHITECTURE

As any other ubiquitous system, the overall system performance and scalability of the library RFID system is highly dependent on the architecture. For instance, the distance between the RFID Antennas and the tags affects the tag coverage, which must be taken in consideration when planning the system [34].

The tag type chosen in this paper is the passive RFID for two simple reasons. First, Passive RFID is more common and its widely applied. They can be found in a wide variety of areas like, airports, libraries, shopping malls, home automation applications, and much more. For instance as of 2009, 1500 libraries employ RFID applications in 2,500 facilities [34-35].

The second reason is the purpose behind this review article, which is to gather as much information as possible about the various RFID technologies and applications. And put them all together in one reference, which can be used later on to build a passive RFID system to be used in a library system to track the library books and different library items.

Fig.1 in the introduction shows the basic structure of an RFID network. The basic component of an RFID network is the Tag, the tags are attached to the items - Or the real-life objects-. Each tag is identified by a unique number that uniquely describes this tag, which makes it easy for the middleware to communicate and store information about the objects. Every tag is bundled with an internal antenna that is used to transmit information to the RFID Reader, and also it participates in powering up the tag by receiving the signal from the reader antenna.

The second component is the RFID Reader Antenna, which can be referred to as the antenna, usually it contains two parts, RFID reader, and antenna. And normally these two components are packaged separately into two component sets (as shown in Fig. 1). The third and last component is the Backend system, which is the application that contains the information about all the tags in the network and manages the flow of information between the tags and the readers.

In the next few sections, all these three components are studied and investigated closely, with one more section that will be added to the end of this chapter to explain a very important concept in RFID; which is collision, and later on, in the same section, a few anti-collision algorithms are discussed.

### 3.1 RFID Tag

RFID tags are passive, active or semi-passive; the term, passive or active describes the power source that the tag uses to extract the required energy to receive and transmit signals. Passive tags retrieve the necessary energy from the signal transmitted by the reader's antenna; depending on the antenna type, the tag retrieves the required energy from the interrogating wave or from a constant signal that some antennas transmit to power up the tag. Passive tags are the cheapest to manufacture, do not require maintenance, and are more compact and lighter [4][21]. The second type of tags is the active tag, which includes a battery as a power source, to enhance reading range.

Semi-passive tag operates similarly to the passive tag, using backscattering technique to reply to the reader. The primary difference is that semi-passive tag has a battery to power a circuitry that is embedded in the tag, which is used in conjunction with externally integrated electronic components such as sensors; Other than that semi-passive tag has the same characteristics of the passive tag (reading range, operating frequency) [22].

Each RFID tag contains an RF transponder with a digital memory chip that is uniquely identified by an Identifier. The interrogator, an antenna packaged with a transceiver and decoder, emits a signal activating the RFID tag in order to read the information saved on this tag, see Fig.3. [4].

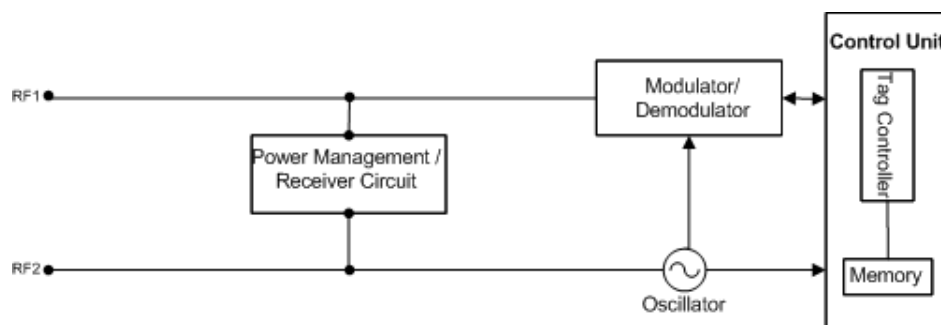

FIGURE 3: BASIC PASSIVE RFID TAG

A brief description of each RFID Tag component is mentioned below:

#### A. RF Interface

It is the radioactive component of the tag, which does the following, see Fig.4:

- Supplying RFID transponders with power by generating the energy required to power up the Tag.
- Modulating the signal for the transponder to transmit.
- Reception and demodulation of signals received from the transponders [36].

#### B. Control unit

The controller part of the reader that performs the following functionalities, (see Fig.3) [36-37]:

- Communication and execution of the application software's commands.
- Signal coding and decoding.
- Communication control with a transponder.
- Some RFID readers have additional functionalities like anti-collision, and encryption.
- Decryption of transferred data, and transponder-reader authentication.
- The data capacity for the RFID tag depends mainly on the manufacturers' specifications. With the current semiconductor revolution, modern tags capacity can save up to 2,048 bits of information [4][36-37].

### 3.2 RFID Reader Antenna

The transmitted signal from the RFID reader antenna is a radio frequency wave that has mixed characteristics of both electrical and magnetic wave, which is why it is publicly known as electromagnetic wave. Based on the characteristics of the transmitted signal, antennas can be divided into two different types:

1. **Linear Polarization:** The transmitted electro-magnetic wave propagates in one direction, vertical or horizontal, depending on the antenna's orientation, which is why they are also called Dipole antennas. This type of antennas is the

best to use when the tag orientation is known; which is why it is used in the hand-held readers in libraries and factories. One disadvantage of this antenna is that the reader and the tag must be aligned for the reader to read the tag [38-39] (See Fig.4.a.).

2. **Circular Polarisation:** In this antenna, the electromagnetic wave covers the two planes when propagating in a circle-like motion (which looks like the motion of a screw). Which makes this type more efficient than the first one for two simple reasons, it covers a wide area, and the tag orientation does not have to be inline with the reader. One disadvantage of this antenna is energy loss; since most of the transmitted signal energy is within the first few waves, as illustrated in Fig.4, where the top figure demonstrate the signal flow of linear polarization antenna. While the bottom figure depicts a signal for Circular polarization antenna, the blue arrows represent the direction of the magnetic field, and the red line is the electromagnetic signal flow [38-39].

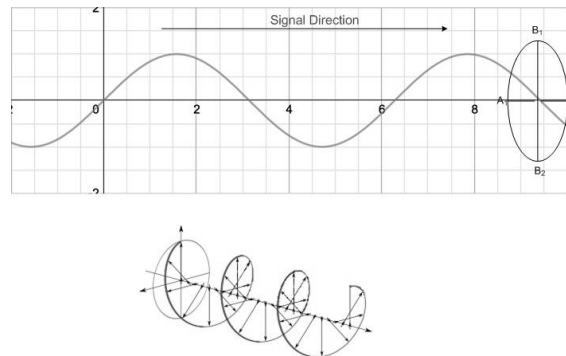

**FIGURE 4: SIGNAL FLOW OF LINEAR POLARIZATION ANTENNA (TOP), CIRCULAR POLARIZATION ANTENNA (BOTTOM)**

Another commercial classification for the antennas divides the antennas into two main groups, based on the number of ports that the antenna has and the transmission direction of the signal on each port:

- 1) **Monostatic Circular:** This antenna uses a common port for transmission and receiving of the RFID signal [39].
- 2) **Bistatic Circular:** This antenna has a dual ports, one for transmission and the other one for receiving signals; this type is common, but its more expensive [39].

Both antennas can be commercially available with an LBT (Listen Before Talk) port, which is a dedicated port that listens for signals before sending RFID signals [39]. The read range for both types depends on:

- 1) The power available at the reader/interrogator to communicate with the tag(s) [40].
- 2) The power available within the tag to respond [40].
- 3) The environmental conditions and structures (the former being more significant at higher frequencies including signal to noise ratio) [40].

The delivered wave from an antenna propagates in space, and the signal strength of it diminishes as the traveled distance increases. The antenna design determines the shape of the wave delivered, so that the read range and the positive identification are also affected by the distance between the antenna and the tag, as well as the orientation of the antenna and the tag. In space free of obstructions or absorption objects, the strength of the field decay in inverse proportion to the cube of the distance, given in Eq. (2) [40]. Another factor that heavily affects the efficiency of the identification is the collision. When an antenna transmits a power signal, regardless if it was a constant power signal or a regular RF signal, all the tags in the range will respond with their identification signal, and for a large number of tags in the same area this will cause a collision, the next chapter section explains this details and also by the end of the section, a few algorithms to solve this issue are proposed.

### 3.3 Collision and Anti-Collision algorithms

Collision is a technical term that describes an event of interference between two or more RFID signals, which normally happens as a result of two or more tags replying to the reader simultaneously. This concept is very important in RFID networks; since all tags in the interrogation zone respond blindly to the reader once the reader sends the power up signal (or



the read signal). As a normal result for the collision, the reader will not be able to read and identify the tag's signal, this implies that a solution must be provided to "detect" or isolate each tag's signal to allow the reader to read those signals separately, such a solution enhances the system efficiency by reducing the identification time. Various anti-collision algorithms have been built based mainly on two categories: (a) ALOHA-based algorithms, which basically divides the frequency range into time slots and assigns a time slot for each tag. (b) Tree-based algorithms; which simply divides the tags into tree-based subsets and iterates through these tags for identification [41-42].

ALOHA algorithm is simply a probability-based algorithm, which belongs to control algorithms of electronic label. A collision resolution algorithm based on Time Division Multiple Access (TDMA) [41].

ALOHA-based algorithms are the most common anti-collision techniques, which is why this document will focus on this type of algorithms. One algorithm in particular will be discussed in details, Dynamic Frame slotted Aloha (DFS-ALOHA) which is one of the most widely used anti-collision algorithms in RFID systems, this technique calculates the probability of the occurrence of the tag-collision to estimate the number of the passive tags, and also the frame size is decided which makes this algorithm the most efficient technique. In DFS-Aloha algorithm, each tag transmits its data in a frame at a random slot to avoid collisions [40][43].

ALOHA divides the bandwidth into frames, and each frame is divided into slots, (see Fig.5). Therefore, the system efficiency strongly depends on the number of tags, and the dynamic frame size that is decided based on the number of tags in the RFID network [44-46]. However, the main disadvantage of ALOHA-based algorithms is "starvation", in which, a tag is not allocated a time slot (or a frequency slot, depending on the Division multiplexing) to transfer its signal, which makes it "hidden" from the reader, in this case, this particular tag will not be identified for a long time, and may be forever [41].

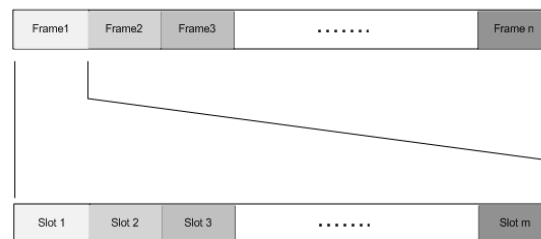

**FIGURE 5: ALOHA-BASED ANTI-COLLISION ALGORITHM**

On the other hand, Tree-based algorithms are deterministic, which identify the tags that lie in the interrogation zone of the antenna using a search tree that classifies all the tags in the zone into a tree of subsets and iterates through these subsets until all tags are identified. Tree-based algorithms can be divided into three main categories, binary tree (BT), query tree (QT) algorithms, and the third category is a composite of both, binary and query tree [21][44][47]. QT uses the tag ID to split the tags into two group of tags, which are called "subsets", which then iterates through all tags by splitting all tags in two groups until all tags are identified, the identification efficiency is significantly affected by the ID distribution. BT uses random numbers to identify the tag splits, which results in tags needing reprogrammable memory to store their assigned number that makes it more efficient, but the cost and size of the tag are higher [48].

### 3.4 RFID Middleware

The Middleware is the core engine that manages the flow of data between tag readers and enterprise applications, and it is responsible operating the integrated components, and managing the flow of information in and out of the repository [36].

It provides readers connectivity, context-based filtering and routing, and interface integration. For efficient tag identification, there are few conditions the middleware should meet in order for the solution to meet the requirements, which can be listed in the [48]:

- Real-time handling of incoming data from the RFID readers: The RFID Middleware should support a wide range of RFID readers, and it should allow the system to interact with these readers in a timely manner [36].
- The middleware must provide a common interface to access different kinds of hardware offering different features.

In the following paragraphs; a general description of the middleware layers will be provided, and two examples for two middleware providers that support our Reader Antenna Infrastructure; one of which is open source middleware solution.

RFID middleware is generally composed of four major layers:

- **Reader Interface:** The lowest layer of the RFID middleware, which handles the interaction with the RFID hardware. It maintains the device drivers of all the devices supported by the system, and manages all the hardware related parameters like reader protocol, air interface, and host-side communication [48].
- **Data Processor and Storage:** Processing and storing the raw data coming from the readers.
- **Application Interface:** Provides the user with the Interface required to configure and manage the RFID Middleware, and the components attached to it.
- **Middleware Management:** Add, configure, and modify connected RFID readers; modify application level
- Parameters such as filters, and duplicate removal timing window; Add or remove services supported by the RFID middleware [48].
- **IBM WebSphere RFID Middleware**

WebSphere RFID middleware solution, designed by IBM, consists of three main components -as shown in Fig.6- : RFID devices, WebSphere Premises Server, and WebSphere Business Integration Server [1].

IBM WebSphere is a sensor-enabled product, meaning that it allows sensor data aggregation and analysis, deriving insights from sensor data and integrating those insights with the SOA business processes. The software provides the use of intelligent business rules that manage complex event identification and processing, which adds more capabilities to the middleware application to integrate with different type of interfaces by just expanding the functionalities of the middleware's APIs.

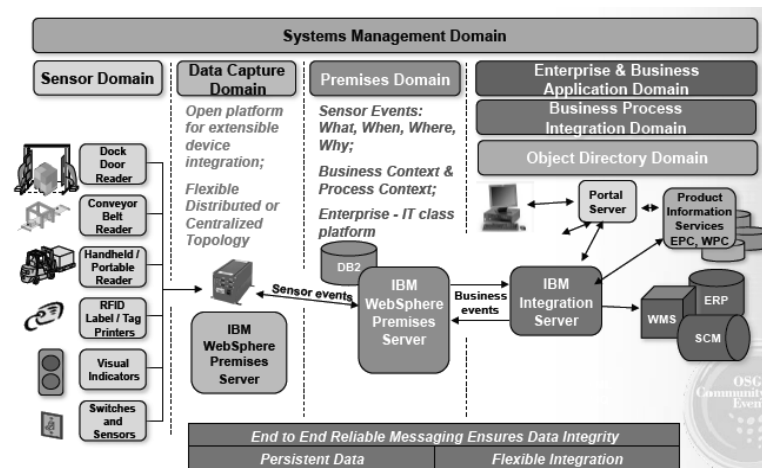

**FIGURE 6: WEBSHERE MIDDLEWARE ARCHITECTURE [1]**

Furthermore, Websphere application server has one more advantage over the other types of servers that are available in the market, it supports a dynamically integrated APIs which allows the application to integrate with different sorts of sensor hardware, it delivers new and enhanced capabilities to create a robust, flexible, and scalable platform for capturing new business value from sensor data [1].

- **Rifidi Edge Server**

Rifidi Edge is a complete RFID Middleware Platform with an edge server and development tools to enable the development and deployment of highly customized RFID applications. The goal of the product is to provide an open source alternative to popular RFID platforms such as IBM Premises Server and Microsoft Biztalk RFID. Built on a cutting edge Java OSGi platform and integrated with a powerful open source rules engine (Esper) Rifidi Edge can build complex applications that interact with the most popular RFID and sensor devices available today [49].

The most basic (and important) function of Rifidi Edge Server is to collect data from sensors, and deliver them to systems that use the data for business processes [49]. The server filters out all the noises and distorted signals that the sensors deliver to the middleware, which is important in the RFID area to filter out all the undesired tag signals.

Fig.7 contains a high-level depiction of how data is collected and the flow through the edge server. The data begin their journey as they are produced by sensors. While these sensors are normally hardware RFID readers, such as Alien 9800, Symbol XR400, and so many others. Data might also be produced by a legacy barcode reader, a database, or even another edge server. The Sensor Abstraction Layer provides a way for users to develop their own programming interface for their custom sensors [49].

As data is collected from the sensors, they are pumped into a high-speed internal message bus, through which other internal edge server components can access them. Because sensors have the ability to produce an enormous number of events, which is why its necessary for the middleware application to confine and filter the incoming data before processing [49].

The Application Layer Events (ALE) specification from EPC global provides a standard API for collecting and filtering RFID data. Rifidi Edge Server has an implementation of the ALE 1.1 specification. Internally, the ALE layer uses an event stream processor called Esper to collect data according to the ALE rules [49-50].

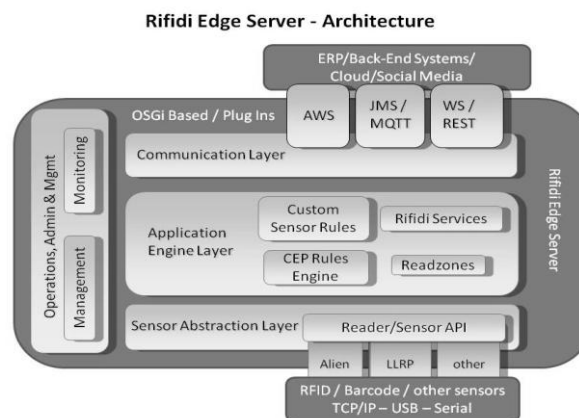

FIGURE 7: EDGE SERVER DATA FLOW [49]

#### IV. SECURITY CONSTRAINTS

The core RFID privacy problem is the unauthorized tag readout. With the help of wireless communication, third parties can read the tags of personal items from large distances, and without any indication that such readout is taking place. Controlling access to tag data is of prime importance [44-45]. By default, most RFID tags are indiscriminate: The tag replies to any reader that transmits a signal that is strong enough to power up this tag [9][48][51].

A few security enhancements that should be followed for secure communication between all library components are listed below:

- **Repository Lookup** of items: The system implements a Database, in which the item's checkout status is logged on a database (With all Tag information). When a customer carries an item through the security gate, the gate identifies the item, accesses the database and confirms that the item has been checked out. This approach requires that each item's full identification number be accessed and relayed to the server for verification (at check out time). This condition will be met when using any of the middleware's mentioned in this paper, because they all use unified repository [9][48].
- **Application Family Identifier (AFI)**: AFI code is assigned to all the RFID tags in the library. When a library security system uses AFI, the gate will request a response from the "checked in" library item. When an item is checked out, the AFI code is modified to disable response to this signal [9][48].
- **Electronic Article Surveillance (EAS)**: Proprietary code is assigned to all RFID Tags inside a library, which should be unique across other libraries and other industries [48][52].

#### V. CONCLUSION

This paper is a review article for all the localization techniques that can be implemented to automate library systems, based on the existing passive RFID Tag infrastructure, and presents a solution to automate a library system. This allows the library administrator to locate the library resources, (or the Tagged library objects) without the necessity to replace the passive RFID tag infrastructure. Also, it allows the librarian to detect any misplaced item in the library at runtime, and using a single

interface. This paper is the baseline to implement a solution, which utilizes the technologies and protocols explained in it to automate a library system.

Based on the technologies and the protocols proposed in this document; the steps to be carried out next can be summarized in one action; Based on the chosen hardware; Find the best simulation software to be used to create a simulation for the solution, which should depict the actual hardware specification, like, operating frequency, read range, noise factor, energy loss, and report the simulation results.

The next step of this research is to build a prototype to translate the design, which can be a cut-down system of the original network of components using the chosen hardware; This will be a proof of concept for the prosperity of the solution.

## REFERENCES

- [1] IBM Corporation, "IBM WebSphere RFID Premises Server V1.0 connects the edge to the enterprise," 2014.
- [2] R. Anee and N. C. Karmakar, "Chipless RFID Tag Localization," *Microwave Theory and Techniques, IEEE Transactions on*, vol. 61, pp. 4008-4017, 2013.
- [3] S. Preradovic and N. C. Karmakar, "Chipless RFID: Bar Code of the Future," *Microwave Magazine, IEEE*, vol. 11, pp. 87-97, 2010.
- [4] J. R. C. Carla R. Medeiros, and Carlos A. Fernandes, "RFID Reader Antennas for Tag Detection in Self-Confined Volumes at UHF," *IEEE Antennas and Propagation Magazine*, vol. Vol. 53, April 2011.
- [5] Q.-u.-a. Mastoi, A. Hassan, and Z. Gul, "Implementation of a wireless sensor network in irrigation system," *Middle East Journal of Business*, vol. 11, pp. 53-57, 2016.
- [6] Z. lixiang, C. Liu, Q. Zhou, J. Hu, H. Xu, and H. Zhang, "International Conference on Advances in Computational Modeling and Simulation Modelling and Simulation of centralized electric vehicle charging station wireless communication networks," *Procedia Engineering*, vol. 31, pp. 746-750, 2012/01/01 2012.
- [7] B. Rundh, "Radio frequency identification (RFID)," *Marketing Intelligence & Planning*, vol. 26, pp. 97-114, 2008.
- [8] R. Want, "An introduction to RFID technology," *Pervasive Computing, IEEE*, vol. 5, pp. 25-33, 2006.
- [9] J. Bohn, "User-centric dependability concepts for ubiquitous computing," University of Karlsruhe, 2006.
- [10] C. Shigang, Z. Ming, and X. Bin, "Efficient information collection protocols for sensor-augmented RFID networks," in *INFOCOM, 2011 Proceedings IEEE*, 2011, pp. 3101-3109.
- [11] J. Khor, W. Ismail, M. N. M. Rashid, A. A. W. Ismail, M. Q. Omar, and F. H. M. Zanal, "UHF RFID proof of concept (POC) with open-source ILS at Universiti Sains Malaysia (USM) Libraries," *Program: Electronic Library & Information Systems*, vol. 49, p. 135, 04// 2015.
- [12] P. Y. Lau, K. K. O. Yung, and E. K. N. Yung, "A smart bookshelf for library RFID system," in *2008 Asia-Pacific Microwave Conference*, 2008, pp. 1-4.
- [13] L. Yuan-Ping and L. Yin-Chang, "Measurement of Effective Reading Distance of UHF RFID Passive Tags," *Modern Mechanical Engineering*, p. 115, 2013.
- [14] A. Barolli, T. Oda, M. Ikeda, L. Barolli, F. Xhafa, and V. Loia, "Node placement for wireless mesh networks: Analysis of WMN-GA system simulation results for different parameters and distributions," *Journal of Computer and System Sciences*, vol. 81, pp. 1496-1507, 12// 2015.
- [15] Z. Yanchao, L. Yunzhong, Z. Yanchao, and S. Jinyuan, "Fast identification of the missing tags in a large RFID system," in *Sensor, Mesh and Ad Hoc Communications and Networks (SECON), 2011 8th Annual IEEE Communications Society Conference on*, 2011, pp. 278-286.
- [16] J. Landt, "The history of RFID," *Potentials, IEEE*, vol. 24, pp. 8-11, 2005.
- [17] M. Bouet and A. L. Dos Santos, "RFID tags: Positioning principles and localization techniques," in *2008 1st IFIP Wireless Days*, 2008, pp. 1-5.
- [18] S. Shuai and R. J. Burkholder, "Item-Level RFID Tag Location Sensing Utilizing Reader Antenna Spatial Diversity," *Sensors Journal, IEEE*, vol. 13, pp. 3767-3774, 2013.
- [19] K. Finkenzeller and D. Müller. (2010). *RFID Handbook : Fundamentals and Applications in Contactless Smart Cards, Radio Frequency Identification and Near-Field Communication (3 ed.)*. Available: <http://AUT.ebib.com.au/patron/FullRecord.aspx?p=547191>
- [20] J.-L. Chen, M.-C. Chen, C.-W. Chen, and Y.-C. Chang, "Architecture design and performance evaluation of RFID object tracking systems," *Computer Communications*, vol. 30, pp. 2070-2086, 6/30/ 2007.
- [21] M. B. Mehdi Ajana El Khaddar, Hamid Harroud and Mohammed Elkoutbi, "RFID Middleware Design and Architecture," *InTech*, p. 384 2011.
- [22] L. M. Ni, Y. Liu, L. Yiu Cho, and A. P. Patil, "LANDMARC: Indoor Location Sensing Using Active RFID," *Wireless Networks*, vol. 10, pp. 701-710, Nov 2004 2004.
- [23] F. Fuschini, C. Piersanti, L. Sydanheimo, L. Ukkonen, and G. Falciaesca, "Electromagnetic Analyses of Near Field UHF RFID Systems," *Antennas and Propagation, IEEE Transactions on*, vol. 58, pp. 1759-1770, 2010.
- [24] Q. Xianming, C. Zhi Ning, and G. Chean Khan, "A UHF near-field/far-field RFID metamaterial-inspired loop antenna," in *Antennas and Propagation Society International Symposium (APSURSI), 2012 IEEE*, 2012, pp. 1-2.

- [25] V. Chawla and H. Dong Sam, "An overview of passive RFID," *Communications Magazine, IEEE*, vol. 45, pp. 11-17, 2007.
- [26] WSO2, "A Reference Architecture for the Internet of Things."
- [27] Q. Xianming, G. Chean Khan, and C. Zhi Ning, "A Broadband UHF Near-Field RFID Antenna," *Antennas and Propagation, IEEE Transactions on*, vol. 58, pp. 3829-3838, 2010.
- [28] H. Liu, Y. Liu, and S. Gong, "An MNG-TL loop antenna for UHF near-field RFID applications," in *Antennas and Propagation (APCAP), 2014 3rd Asia-Pacific Conference on*, 2014, pp. 473-475.
- [29] J. Singh, N. Brar, and C. Fong, "The state of RFID applications in libraries," *Information Technology & Libraries*, vol. 25, pp. 24-32 9p, 2006.
- [30] L. Xiao zheng, X. Zeming, and C. Xuanliang, "A Compact RFID Reader Antenna for UHF Near-Field and Far-Field Operations," *International Journal of Antennas and Propagation*, vol. 2013, p. 5, 2013.
- [31] E. Commission, "Visions and Challenges for Realising the Internet of Things," *CERP-IoT*, 2010.
- [32] Z. Xing, L. Wang, C. Wu, J. Li, and M. Zhang, "Characteristics and Application of a Novel Loop Antenna to UHF RFID Receivers," *International Journal of Antennas and Propagation*, vol. 2011, p. 7, 2011.
- [33] D. Caldwell-Stone, "RFID in Libraries," *Library Technology Reports*, vol. 46, pp. 38-46, Nov/Dec Nov/Dec 2010 2010.
- [34] K. V. S. Rao, P. V. Nikitin, and S. F. Lam, "Antenna design for UHF RFID tags: a review and a practical application," *Antennas and Propagation, IEEE Transactions on*, vol. 53, pp. 3870-3876, 2005.
- [35] K. N. Moncombu Ramakrishnan, "Performance benchmarks for passive UHF RFID tags," *ProQuest Dissertations & Theses Global*, 2005.
- [36] T. Bouhouche, M. Boulmalf, M. Bouya, and M. Elkoutbi, "A new middleware architecture for RFID systems," in *Microwave Symposium (MMS), 2014 14th Mediterranean*, 2014, pp. 1-7.
- [37] W. Haifeng and Z. Yu, "Passive RFID Tag Anticollision Algorithm for Capture Effect," *Sensors Journal, IEEE*, vol. 15, pp. 218-226, 2015.
- [38] B. K. Mishra, V. A. Bharadi, B. Nemade, K. H. Krishna, Y. S. Babu, and T. Kumar, "Proceedings of International Conference on Communication, Computing and Virtualization (ICCCV) 2016 Wireless Network Topological Routing in Wireless Sensor Networks," *Procedia Computer Science*, vol. 79, pp. 817-826, 2016/01/01 2016.
- [39] SkyRFID. (2007-2015). *RFID Reader Antenna Tutorial - What you need to know*. Available: [http://skyrfid.com/RFID\\_Antenna\\_Tutorial.php](http://skyrfid.com/RFID_Antenna_Tutorial.php)
- [40] H. Yejun and W. Xiaoye, "An ALOHA-based improved anti-collision algorithm for RFID systems," *Wireless Communications, IEEE*, vol. 20, pp. 152-158, 2013.
- [41] C. Wen-Tzu, "An Accurate Tag Estimate Method for Improving the Performance of an RFID Anticollision Algorithm Based on Dynamic Frame Length ALOHA," *Automation Science and Engineering, IEEE Transactions on*, vol. 6, pp. 9-15, 2009.
- [42] W. Jianwei, W. Dong, Z. Yuping, and T. Korhonen, "Fast Anti-Collision Algorithms in RFID Systems," in *Mobile Ubiquitous Computing, Systems, Services and Technologies, 2007. UBIKOMM '07. International Conference on*, 2007, pp. 75-80.
- [43] C. Tao and J. Li, "Analysis and Simulation of RFID Anti-collision Algorithms," in *Advanced Communication Technology, The 9th International Conference on*, 2007, pp. 697-701.
- [44] H. Xu and L. Son, "Efficient Dynamic Framed Slotted ALOHA for RFID Passive Tags," in *Advanced Communication Technology, The 9th International Conference on*, 2007, pp. 94-97.
- [45] D.-g. Zhang, G. Li, Z.-h. Pan, and Y.-p. Liang, "A new anti-collision algorithm for RFID tag," *International Journal of Communication Systems*, vol. 27, pp. 3312-3322, 2014.
- [46] S. Weilian, N. Alchazidis, and T. T. Ha, "Multiple RFID Tags Access Algorithm," *Mobile Computing, IEEE Transactions on*, vol. 9, pp. 174-187, 2010.
- [47] L. Yuan-Cheng and H. Ling-Yen, "General binary tree protocol for coping with the capture effect in RFID tag identification," *Communications Letters, IEEE*, vol. 14, pp. 208-210, 2010.
- [48] E. W. T. Ngai, K. K. L. Moon, F. J. Riggins, and C. Y. Yi, "RFID research: An academic literature review (1995-2005) and future research directions," *International Journal of Production Economics*, vol. 112, pp. 510-520, 1/1/2008 2008.
- [49] RifiDiEdgeServer, "RifiDi Edge Server User's Guide," 2015.
- [50] M. Langheinrich, "A survey of RFID privacy approaches," *Personal and Ubiquitous Computing*, vol. 13, pp. 413-421, Aug 2009 2009.
- [51] I. 28560-1, "Information and documentation -- RFID in libraries -- Part 1: Data elements and general guidelines for implementation," *ISO*, 2011.
- [52] X. Zhu, S. K. Mukhopadhyay, and H. Kurata, "A review of RFID technology and its managerial applications in different industries," *Journal of Engineering and Technology Management*, vol. 29, pp. 152-167, 1// 2012.