

# Kalman Filter Based Approach of a signal by removing ICI for OFDM Channel

Mr. Lokesh Kumar<sup>1\*</sup>, Dr. Javed Khan Bhutto<sup>2</sup>, Mr. Gautam Pandit<sup>3</sup>

<sup>1</sup>M.Tech Scholar, Digital Communication, Marudhar Engineering College, Bikaner.

<sup>2</sup>Principal & HOD, Department of EE, Marudhar Engineering College, Bikaner.

<sup>3</sup>M.Tech coordinator, Department of ECE, Marudhar Engineering College, Bikaner.

**Abstract**— This paper deals with the case of a high speed mobile receiver operating in an orthogonal-frequency division multiplexing (OFDM) communication system. The OFDM communication is very much inspired from the channel frequencies over the network. In such network some kind of orthogonal distortion occurs over the channel called Inter carrier Interference. Here we will improve the ICI using Kalman Filtering improved by using repetitive slot and correlated channel tap.

The proposed work of this paper is when data travel over some channel it suffers from the problem of interference. The interference results the high signal to noise ratio as well as high bit error rate. The proposed system will improved the signal by removing the different kind of impurities over the signal. These impurities include the ICI, PAPR and the noise over the signal. The signal will be more effective than standard OFDM. So we needn't many pilot symbols in practice, still can ensure the algorithm performance and reduce the time- delay and complexity of this algorithm.

**Keywords**— Kalman Filter, OFDM Channel, mobile receiver, repetitive slot, interference, signal to noise ratio.

## I. INTRODUCTION

ORTHOGONAL frequency division multiplexing (OFDM) is an effective technique for high bit-rate transmission. In mobile communications, high speeds of terminals cause Doppler effects that could seriously affect the performance. In such case, dynamic channel estimation is needed, because the radio channel is frequency selective and time-varying, even within one OFDM symbol. It is thus preferable to estimate channel by inserting pilot tones, called comb-type pilots, into each OFDM symbol. Orthogonal frequency division multiplexing (OFDM) is a multicarrier modulation (MCM) technique which seems to be an attractive candidate for fourth generation (4G) wireless communication systems. OFDM offer high spectral efficiency, immune to the multipath delay, low inter-symbol interference (ISI), immunity to frequency selective fading and high power efficiency. However OFDM system suffers from serious problem of high PAPR. In OFDM system output is superposition of multiple sub-carriers. In this case some instantaneous power output might increase greatly and become far higher than the mean power of system. To transmit signals with such high PAPR, it requires power amplifiers with very high power scope. These kinds of amplifiers are very expensive and have low efficiency-cost. If the peak power is too high, it could be out of the scope of the linear power amplifier. This gives rise to non-linear distortion which changes the superposition of the signal spectrum resulting in performance degradation. If no measure is taken to reduce the high PAPR, MIMO-OFDM system could face serious restriction for practical applications. PAPR can be described by its complementary cumulative distribution function (CCDF). In this probabilistic approach certain schemes have been proposed by researchers. These include clipping, coding and signal scrambling techniques. Under the heading of signal scrambling techniques there are two schemes included.

OFDM represents a different system design approach. It can be thought of as a combination of modulation and multiple-access schemes that segments a communications channel in such a way that many users can share it. Whereas TDMA segments are according to time and CDMA segments are according to spreading codes, OFDM segments are according to frequency. It is a technique that divides the spectrum into a number of equally spaced tones and carries a portion of a user's information on each tone. A tone can be thought of as a frequency, much in the same way that each key on a piano represents a unique frequency. By allowing the tones to overlap, the overall amount of spectrum required is reduced.

## II. POLYNOMIAL MODELING IN MIMO OFDM SYSTEM

In wireless communication especially in MIMO system the channel modeling is the key area and needs great effort. The main objective of MIMO technology is to increase capacity which is depending on decorrelation properties between antennas and the full rankness of the channel matrix. To fully understand channel behaviour and then we extract formula which represents the channel and to determine the impact of the propagation parameters on the capacity of the channel.

Good channel modeling clearly put the following points:

- It is exactly put the capacity of outdoor and indoor MIMO channel.
- Identifies the important parameters governing capacity.
- Put very simplify conditions to get full rank.

In MIMO systems, a transmitter sends multiple streams by multiple transmit antennas. The transmit streams go through a matrix channel which consists of multiple paths between multiple transmit antennas at the transmitter and multiple receive antennas at the receiver. Then, the receiver gets the received signal vectors by the multiple receive antennas and decodes the received signal vectors into the original information. Here MIMO system model:

$$\mathbf{Y} = \mathbf{H}\mathbf{X} + \mathbf{G} \quad (1)$$

Where  $\mathbf{Y}$  and  $\mathbf{X}$  are receive and transmit vectors,  $\mathbf{H}$  and  $\mathbf{G}$  are the channel matrix and noise vector, respectively.

A 3×3 channel matrix is given by

$$\mathbf{H} = \begin{pmatrix} h_{11} & h_{12} & h_{13} \\ h_{21} & h_{22} & h_{23} \\ h_{31} & h_{32} & h_{33} \end{pmatrix}$$

### III. OFDM SYSTEM MODEL

A baseband OFDM signal can be represented by [1]

$$b(t) = \sum_{i=1}^{N-1} A_i \cos(\omega_i t + \phi_i)$$

Where  $A_i$  is the amplitude,  $\omega_i = 2\pi f_i$  is the angular frequency,  $\phi_i$  is the phase of the  $i^{\text{th}}$  sub-carrier, and  $N$  is the number of sub-carriers. According to the modulation technique to be used, either  $A$  or  $\phi$  is determined by the data. Now, the baseband OFDM signal  $b(t)$  is modulated next, onto a RF carrier with frequency  $f_c$ :

$$\begin{aligned} s(t) &= 2b(t)\cos\omega_c t \\ &= 2\sum_{i=0}^{N-1} A_i \cos(\omega_i t + \phi_i)\cos\omega_c t \\ &= \sum_{i=0}^{N-1} A_i \left\{ \cos[(\omega_c + \omega_i)t + \phi_i] + \cos[(\omega_c - \omega_i)t - \phi_i] \right\} \end{aligned}$$

where  $\omega_c = 2\pi f_c$ , and we assume the phase of the carrier to be zero for simplicity. Since a single side band transmission is enough to carry the information in  $A_i$  or  $\phi_i$ , it is assumed that the upper sideband is used, and therefore the transmitted signal can be represented as

$$s(t) = \sum_{i=0}^{N-1} A_i \cos[(\omega_c + \omega_i)t + \phi_i]$$

In this section the theoretical analysis of the effects of frequency errors is presented. The maximum Doppler shift occurs when the two mobile nodes move toward each other, given by [6]

$$f_d = \frac{vf_c}{c}$$

Where  $v$  is the relative speed of the two nodes,  $f_c$  is the carrier frequency and  $c$  is the speed of light ( $3 \times 10^8$  ms). An OFDM signal consists of numerous sub-carriers with different frequencies. The amount of Doppler shift affecting the  $i^{\text{th}}$  sub-carrier is given by [7].

$$(f_c \pm f_i) \longrightarrow (1 + \xi)(f_c \pm f_i)$$

where  $\xi$  is the percentage of the change in frequency and is determined by

$$\xi = \frac{f_d}{f} = \frac{v}{c} \cos \theta$$

The right-hand side of Equation can be written as

$$(1 + \xi)(f_c \pm f_i) = (1 + \xi) f_c \pm (1 + \xi) f_i$$

Which demonstrates that the Doppler frequency shift affects the carrier frequency and the sub-carrier frequencies by the same percentage  $\xi$ . The Doppler shift of the carrier frequency can be calculated as

$$f_{dc} = \frac{vf_c}{c} \cos \theta$$

and the Doppler shift of the sub-carrier frequencies as

$$f_{di} = \frac{vf_i}{c} \cos \theta$$

By using Equation again, the transmitted OFDM signal with Doppler shift can be written as

$$s(t) = \sum_{i=0}^{N-1} A_i \cos[(1 + \xi)(\omega_c + \omega_i)t + \phi_i]$$

$$= \sum_{i=0}^{N-1} \{ A_i \cos[(1 + \xi)\omega_i t + \phi_i] \cos[(1 + \xi)\omega_c t] - A_i \sin[(1 + \xi)\omega_i t + \phi_i] \sin[(1 + \xi)\omega_c t] \}$$

In Equation,  $A_i \cos [(1+\xi) \omega_i t + \phi_i]$  can be thought of as the envelope of the carrier,  $\cos [(1+\xi) \omega_c t]$ , which helps to demonstrate that the Doppler shift affects the envelope and the carrier frequency by the same percentage. The Doppler shift also affects the symbol rate and the time synchronization.

**3.1 Design of An OFDM System :**

The design of an OFDM system requires a trade-off between various parameters as like in all communication system design. Usually, the input parameters to the design are the bit rate, available bandwidth and the maximum delay spread introduced by the channel. The design involves calculation of symbol duration, guard time, number of sub-carriers and the modulation and coding schemes among others.

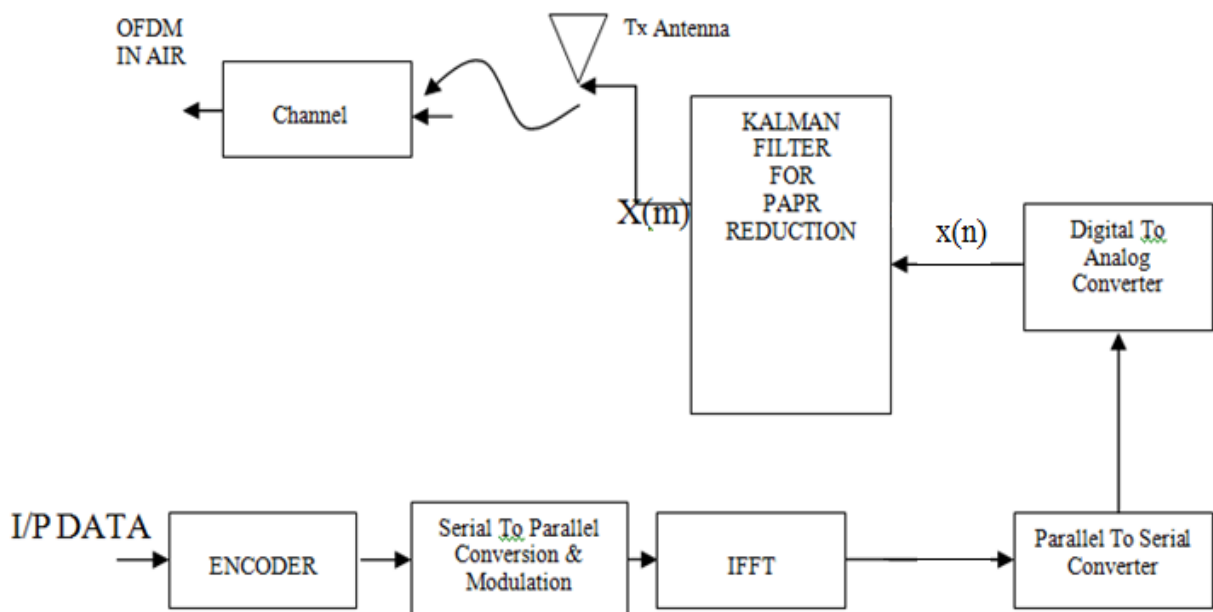

**FIGURE 1: Block Diagram of OFDM Transmitter**

### IV. KALMAN FILTER

Kalman filter is basically designed as a generalized solution to the common problem. It is about to estimate the state of discrete time controlled process by using the basic concept of differential equations. The basic equation followed by Kalman Filter is given as

$$K_k = P_k^- H_k^T (H_k P_k^- H_k^T + V_k R_k V_k^T)^{-1}$$

$$\hat{x}_k = \hat{x}_k^- + K_k \left( z_k - h \left( \hat{x}_k^-, \mathbf{0} \right) \right)$$

$$P_k = (I - K_k H_k) P_k^-$$

### V. SIMULATION RESULTS

In this section, we verify the theory by simulation and we Test the performance of the iterative algorithm.

In figure, comparative analysis of PAPR reduction is shown using Kalman Filter. In this work we have implemented a two stage Kalman Filter. The first stage is about to reduce the PAPR. The result shows that the presented approach is more effective with less SNR over the signal.

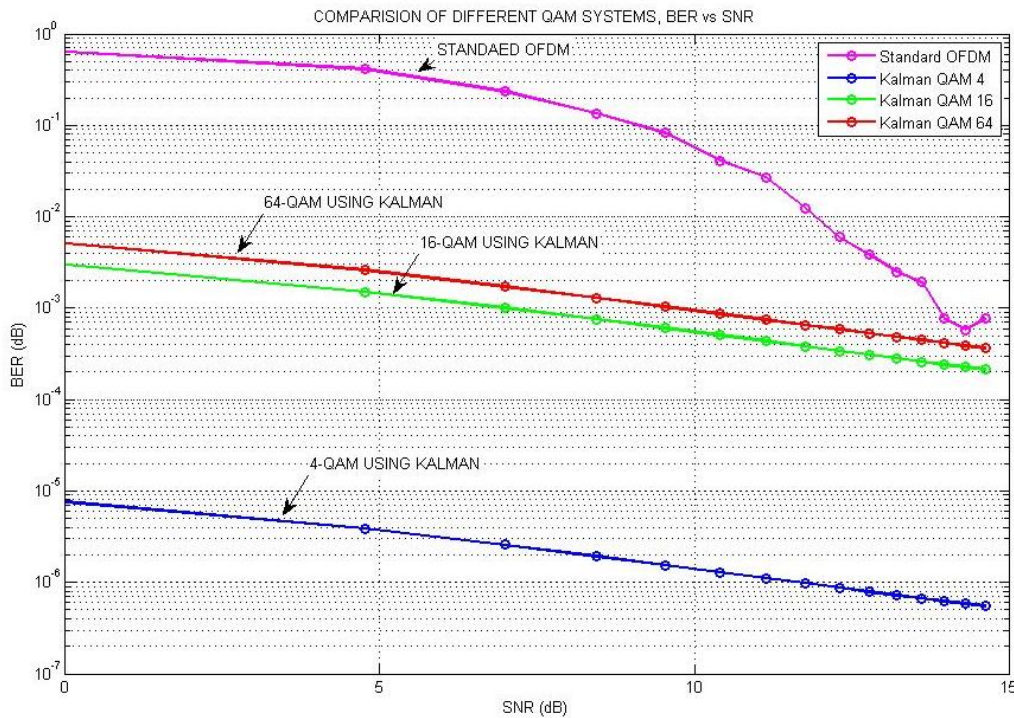

**FIGURE 2: Comparison of different QAM Systems, BERvs SNR**

When data travel over some channel it suffers from the problem of interference. The interference results the high signal to noise ratio as well as high bit error rate. The proposed system will improved the signal by removing the different kind of impurities over the signal. These impurities include the ICI, PAPR and the noise over the signal. The signal will be more effective than standard OFDM.

### VI. CONCLUSION

In this project, the performance of OFDM systems in the presence of frequency offset between the transmitter and the receiver has been studied in terms of the Carrier-to-Interference ratio (CIR) and the bit error rate (BER) performance. Inter-carrier interference (ICI), which results from the frequency offset, degrades the performance of the OFDM system.

One method is explored in this project for mitigation of the ICI i.e. ICI self-cancellation (SC). By using this method the BER is improved in comparison to simple OFDM system.

In this project, the simulations were performed in an AWGN channel. This model can be easily adapted to a flat-fading channel with perfect channel estimation. Performing simulations to investigate the performance of this ICI cancellation schemes in multipath fading channels without perfect channel information at the receiver can do further work.

## REFERENCES

- [1] H. Hijazi and L. Ros, "Time-varying channel complex gains estimation and ICI suppression in OFDM systems" in IEEE GLOBAL COMMUNICATIONS Conf., Washington, USA, Nov. 2007.
- [2] H. Hijazi and L. Ros, "Polynomial estimation of time-varying multipath gains with intercarrier interference mitigation in OFDM systems" in IEEE Trans. Vehic. Techno., vol. 57, no. 6, November 2008.
- [3] A. R. S. Bahai and B. R. Saltzberg, Multi-Carrier Dications: Theory and Applications of OFDM: Kluwer Academic/Plenum, 1999.
- [4] M. Hsieh and C. Wei, "Channel estimation for OFDM systems based on comb-type pilot arrangement in frequency selective fading channels" in IEEE Trans. Consumer Electron., vol.44, no. 1, Feb. 1998.
- [5] Z. Tang, R. C. Cannizzaro, G. Leus and P. Banelli, "Pilot-assisted timevarying channel estimation for OFDM systems" in IEEE Trans. Signal Process., vol. 55, pp. 2226-2238, May 2007.
- [6] S. Tomasin, A. Gorokhov, H. Yang and J.-P. Linnartz, "Iterative interference cancellation and channel estimation for mobile OFDM" in IEEE Trans. Wireless Commun., vol. 4, no. 1, pp. 238-245, Jan. 2005.
- [7] B. Yang, K. B. Letaief, R. S. Cheng and Z. Cao, "Channel estimation for OFDM transmisson in mutipath fading channels based on parametric channel modeling" in IEEE Trans. Commun., vol. 49, no. 3, pp. 467-479, March 2001.
- [8] E. Anderson and Z. Bai, LAPACK User's Guide: Third Edition,SIAM, Philadelphia, 1999.
- [9] Wikipedia contributors,"Linear regression", Wikipedia, The Free Encyclopedia.
- [10] K. E. Baddour and N. C. Beaulieu, "Autoregressive modeling for fading channel simulation" in IEEE Trans. Wireless Commun., vol. 4, no. 4, pp. 1650-1662, July 2005.
- [11] B. Anderson and J. B. Moore, Optimal filtering, Prentice-Hall, 1979.
- [12] W. C. Jakes, Microwave Mobile Communications. Piscataway, NJ: IEEE Press, 1983.