

Parameter Configuration Researched of Sludge Drying Treatment System on the Screw Press

Qu Qingwen¹, Hu Xiaoqing², Lin Chunmei³

Yantai Nanshan University, Machinery Department, Yantai Longkou Shandong P R China

Abstract— The basic idea of modular design is applied to the planning and analysis of the screw press sludge treatment system in this paper. A combination mode of sludge treatment system is obtained. The functional modules of the system are formed. The interface information relation of each module is analyzed by system function. The process parameters of each module were precisely configured according to the dry requirements of sludge treatment and the initial sludge concentration. The transfer relationship between modules is achieved. The control parameters are determined according to the transfer relationship. The parameter basis is provided for the control design of the system.

Keywords— Screw Process, Sludge drying treatment system, machinery, sludge concentration, control system.

I. INTRODUCTION

The disposal of sludge is a prominent problem in current environmental protection management. How do sewage treatment plants face the problem of producing a large amount of surplus sludge every day? Due to its large quantity of production, difficulty in transferring and disposal, and the high cost of disposal, it is the focus of the work of enterprises and environmental protection departments at all levels^[1-2].

Improving the concentration and dehydration efficiency of wastewater has become an important issue to realize circular economy and sustainable development. By means of mechanical compression, the mud or viscous liquid mixture is separated into solid and liquid operations, which is called squeezing dehydration. It is an effective method for high dewatering in solid-liquid separation technology. Through the improvement and optimization of the researchers, it has been widely used in the fields of chemical industry, metallurgy, energy, dyestuff, food, pharmacy and sludge treatment^[3]. The theory of screw squeeze is mainly used in the oil and juicing of crops^[4]. It is still in the initial stage to use this technology for sludge dewatering in the process of sludge dewatering. Theoretical research is not yet perfect. At present, the research in this field mainly focuses on the design of screw press structure, optimization and improvement of experiments and analysis through simulation software. Many scholars have made great progress. The relationship between the use of flocculant and the effect of dehydration was studied by Jaroslav Boráň. The use of flocculant was found under different working conditions. It is helpful to optimize the performance of screw press^[5]. Li tong carried out a flocculant screening test and sludge dewatering test in gaobeidian sewage treatment plant. The following conclusions are drawn. Improving the rate of flocculating agent can improve the dewatering performance of the screw press dehydrator. The speed of the screw can be increased appropriately, and the transmission speed of the sludge in the drum is accelerated. The speed of the screw can be increased appropriately, and the transmission speed of the sludge in the drum is accelerated. So it increases the throughput. But if the speed is too fast, it will cause the export pressure drop. Thus, the moisture content of mud cake increases^[6].

In addition to the above research results, some new research directions have been developed in the field of spiral squeezing sludge dewatering. Such as discrete element method, pelease /Thickening theory is applied^[7]. However, most of the sludge dewatering only analyzes the single equipment, and there is no systematic process analysis^[8]. In this paper, the function of the system is studied by modularization analysis technique. A modular sludge drying treatment system is designed. The module division and function analysis are carried out for each process of the system. The technical requirements and parameter configuration of the screw pressing technology in the sludge drying system are discussed. A new system of mechanical dehydration was established. Furthermore, the efficiency of sludge dewatering is improved. The dry degree of higher final sludge was obtained.

II. ANALYSIS OF THE DRYING PROCESS SYSTEM OF SCREW PRESS SLUDGE

The sludge drying process is mainly to realize the separation of mud and water. Water can be reused. Sludge can be reused after drying and decrement. The pollution of the sludge was eliminated. The sludge system of this study can deal with muddy water mixture with impurity content of more than 3%. Finally, it is required to get the impurity mud with the dry degree >40%. This will enable the reuse of sludge and filtered water.

The composition of sludge treatment system is shown in 'Figure1'. According to the function of the system, it mainly includes the sludge modulation processing system, the first-level dehydration system, the squeezing dehydration system and the control system.

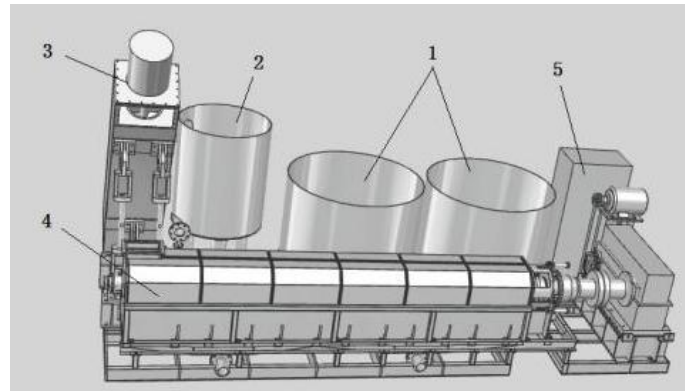

FIGURE1. SCHEMATIC DIAGRAM OF SLUDGE SCREW PRESS PROCESSING SYSTEM

1-Flocculant dissolving system, 2-Flocculation system, 3-Primary dehydration system, 4-Screw extrusion dehydration system, 5-Control system

In addition, it also includes auxiliary systems such as sludge tank and separating water and dewatering sludge. The overall operating condition of the system is shown in 'Figure 2'.

In sludge treatment system, the parameters of sludge are mainly mud content. The parameters associated with the process are fiber content. Fiber content is related to the breakdown of flocculation. In the treatment of sewage, the initial sludge content is generally uncertain, and is changed within a certain range. For example, the amount of sewage in papermaking is above 3%. Therefore, in most cases, the sludge tank is set up. The concentration of the whole pool is used as the basis for analysis. Its concentration is tested online by sensing technology. The measured value is an important parameter of control system design. The sludge modulation system consists of two parts, flocculant modulation system and flocculation process. Flocculant modulation system generally consists of particle flocculant quantification, solvent quantification, dissolving pool, proportioning pump and so on. The flocculant is generally solid, and the dissolution time is long, so the solution pool must be set. Flocculation process is the process of full mixing of sludge and flocculation solution. A variety of flocculators can be used at present. The sludge is agglomerated to form a flocculation with certain strength. The formation is separated from some water. The primary dehydration system is connected with the flocculator. After flocculation, the mixture enters the first stage of dehydration. In this study, the oblique helical device was used as the primary dehydration. The concentration of the outlet sludge is adjusted by adjusting the Angle of oblique helix. The purpose is to adapt to the requirements of subordinates. The screw press system is used as a terminal dewatering.

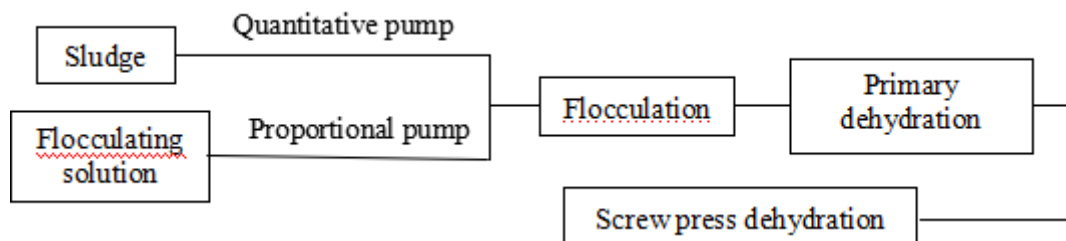

FIGURE 2. SCHEMATIC DIAGRAM OF SYSTEM OPERATION

III. MODULAR ANALYSIS OF SLUDGE DEWATERING SYSTEM

According to the function of the system, the whole system is divided into mud storage module, flocculant module, flocculant adequate supply module, water supply module, flocculation module, the level of dehydration module, interface module, screw press dehydration module and control module, etc. The functions of each module are shown in table 1.

Sludge
 Flocculation liquid
 Proportional pump

TABLE 1
FUNCTION ANALYSIS OF SLUDGE DEWATERING SYSTEM

Module		Function
Water storage		Storage of initial sewage. The storage capacity is designed according to the production capacity of the system.
Water supply		According to the production capacity and the sludge concentration, the pump delivery system is designed with adaptive function and flow control.
The dissolution of the flocculant	Flocculant addition	The flocculant is automatically added according to the solubility requirement.
	The water supply	According to the solubility requirement, the clean water is automatically added according to certain proportion.
	Dissolution time	According to the properties of flocculants, the dissolution time is generally controlled at 45~120min.
Flocculant solution supply		The pump and flow control system is adopted. The adaptive control is realized according to the sewage flow.
Flocculation		The flocculator are used in this module. The full and uniform mixing and mixing time of sludge and flocculant must be guaranteed.
Primary dehydration		The oblique helical device is used. According to the production capacity analysis, the modular design of the module is carried out, single row, double row or row. Water content and yield can be adjusted. The water content will be adjusted by adjusting the oblique Angle of the oblique spiral. The output is obtained by adjusting the rotational speed.
Interface		Through the interface, the sludge transfer between the oblique spiral and the squeeze screw is completed. The continuous and adaptive control of sludge will be realized.
Screw press		The final squeeze of the sludge will be finished. The speed control is realized in the screw system to meet the requirements of different sludge and different drying degree.
Dry mud conveying		The transport and storage of dry mud will be completed.
Control		The whole machine is controlled by PLC or main engine.

IV. DETERMINATION OF SYSTEM PROCESS PARAMETERS

The process parameter is the guarantee of the stable operation of the system. The process parameters are determined according to the actual production capacity requirements. The sludge treatment system is based on the requirement of sludge treatment. The initial amount of sludge or the production capacity of the final squeeze screw can be used as a process control parameter. This provides the basis for control parameter design. At the same time, the parameter design basis of each control point of the system can be provided.

4.1 Production capacity and press screw parameter configuration.

This study is based on the analysis of terminal sludge treatment. The analysis of the squeezing screw, the basic parameters are the rotational speed, compression ratio, inlet and outlet sectional area, and pitch. The compression ratio is determined by the ratio of the water content of the inlet. Its production capacity is defined as the volume of the first spiral.

$$Q = \frac{\pi D_1 A n \gamma \varphi c}{\cos \beta} \quad (1)$$

D_1 -The average diameter of spiral first pitch. A -The average section area of spiral first pitch. n -speed, γ -The bulk of dry mud., φ -Filling coefficient, c -The entrance concentration.

Theoretical compression ratio is the ratio of the end to the initial spiral void volume.

$$\alpha = V_1 / V_i \quad (2)$$

Compression ratio is selected in the following analysis, $\alpha=4$. The control parameters are shown in table 2.

TABLE 2
CONTROL PARAMETERS OF PRESS SCREW

Speed (rpm)	Export production (t/d)	Absolute dry mud (t/d)	The entrance concentration (%)	Flow (t/h)	Flow (m ³ /h)	Export concentration (%)
0.29	5	2.5	13.3	0.783	0.766	50
1.47	26	13	13.3	4.073	3.982	50

Note: the data in table 2 is calculated based on the total output analysis. The first line is calculated when the output is 5t/d. The second line is calculated when the output is 26t/d. In the analysis of the screw press module, in addition to the shape of the module itself, the production capacity is determined by the spindle speed. In general, frequency conversion is adopted on the main shaft. The production capacity is related to the selection of the module, and the range of production capacity is related to the change of motor frequency. After the module is determined, the compression ratio is a fixed value. Therefore, it is very important to control the inlet concentration during the design analysis. The squeezing screw module is generally composed of sub-modules, such as press screw, variable frequency motor, transmission (deceleration system), etc. The transmission form can be determined according to the nature of the actual sludge by any combination of belt drive, reducer and chain drive. The speed of the best treatment is obtained. The speed of the optimum sludge treatment is obtained. After the speed is determined, the type of screw is determined according to the yield. The output of this paper is based on the number of tons per day, which means that there is no water pure mud. The flow in the table is expressed in two ways: t/d or m³/d.

4.2 Primary dehydration system - parameter matching of oblique spiral module

The inlet parameters of the screw press are provided by the first-level dehydration module. The final sludge moisture content is guaranteed by inlet parameters. Compression ratio is the fixed value after the press screw module is determined. At this point, the export concentration is determined by the entrance concentration. Two basic parameters must be guaranteed by the first level dehydration module, i.e., output concentration and output. The control parameters of the oblique spiral module are shown in table 3.

TABLE 3
CONTROL PARAMETERS OF OBLIQUE SPIRAL

The entrance concentration (%)	Inlet mud flow (t/h)	Export concentration (%)	The inner diameter of the screen (mm)	Helical root diameter (mm)	Pitch (mm)	Speed (rpm)	Modular number of modules
4.3	2.39583	13.3	165	65	120	18.42	1
4.3	12.45833	13.3	165	65	120	47.89	2

Note: the data in table 3 is calculated based on the total output analysis. The first line is calculated when the output is 5t/d. The second line is calculated when the output is 26t/d. For example, the inlet concentration is calculated from the two parts of sewage and potion. The outlet concentration must be compatible with the inlet concentration of the press screw. The speed term refers to the use of single row of oblique helical parameters; double row can be reduced double. In the research, the helical screw module has been standardized and can be combined to meet the production capacity requirements. The same combination of modules should be used to facilitate the installation and adjustment of the equipment. By changing the inclination angle of the spiral, the export concentration is corrected. The change of speed is a two-way influence on production capacity and export concentration, which must be adjusted accurately in production.

4.3 Parameter configuration of flocculation module

In the sludge treatment system, the flocculation module is an important module to complete the coagulation of the sludge, so that the sludge mass is separated from the water. The parameters of the flocculation module are shown in table 4.

TABLE 4
PARAMETER CONFIGURATION OF FLOCCULATION MODULE

Enter the concentration of the mud (%)	Flow into the mud (m ³ /h)	Drug concentration (%)	Incoming flow (m ³ /h)	Postmixed concentration (%)	Outlet flow (t/h)
5	2.08333	0.1	0.4166	4.3	2.39583
5	10.8333	0.1	2.1666	4.3	12.45833

The first line is calculated when the output is 5t/d. The second line is calculated when the output is 26t/d. The mud concentration of the flocculator is the concentration of sludge tank. The inlet flow of sludge is calculated according to the production capacity. The dilution concentration of flocculant was selected as 0.1%, according to the type of flocculant and the actual dosage. The concentration of sludge outlet in flocculator was about 4.3%. The time and uniformity of flocculation must be guaranteed to obtain good flocculation quality. The effect of the dehydration effect on the first stage dewatering helical module is significant.

4.4 The parameter configuration of the dissolving module

The dissolving module of flocculant includes the additive module, the water supply module, the control module, etc. The parameter configuration is shown in table 5.

Note: The first line is calculated when the output is 5t/d. The second line is calculated when the output is 26t/d. Dosage is based on sludge characteristics and flocculation effect to determine. In this paper, flocculant was applied to the sludge treatment by 4kg/t, which was calculated according to the amount of dry mud. The determination of concentration is related to the drug supply flow, and the concentration is determined according to the size and type of the dilution pool. In general, the lower the concentration, the more uniform the mixture of sludge and solution, the shorter the flocculation time.

TABLE 5
PARAMETER CONFIGURATION OF FLOCCULANT DISSOLVING MODULE

Concentration of dissolved (%)	The dosage (m ³ /d)	Flow (m ³ /h)	Flocculant dosage (kg/d)	Usage time (h/m ³)
0.1	10	0.41667	10	2.4
0.1	52	2.16667	52	0.4615

V. CONCLUSION

Sewage treatment technology is a worldwide technical problem. It is desirable to make full use of the sludge to the environment. Sludge treatment system is used, sludge reduction can be realized. The purpose of the sludge can be determined according to the nature of the sludge. For example, paper sludge containing fiber can be incinerated to generate electricity. The sludge contains less pollutants and can be returned to the field or fertilizer after treatment. Industrial sludge must be treated harmlessly to be used. The process control parameter of this paper is calculated by the parameterized program, which is the result of the comprehensive process analysis, and only provides reference for design module selection. The combined parameter chain of the actual system should be analyzed and calculated according to the requirements of the production process, and the necessary experiments should be carried out to modify the parameters. Through parameter configuration analysis, the design parameters of control system can be determined, and the time of design system can be shortened effectively, and the success rate of system combination design is greatly improved.

REFERENCES

- [1] Zhang Y L, Yang L, Liu B Y and C M Zhao 2009 *Heilongjiang Pulp & Paper*. 2 53-56.
- [2] Tang L S, Luo Z G, Zhang L J, Song J and L X Deng 2016 *Technology of water treatment* .42 12-17
- [3] Ding Q S, Wang W Y, 2000 *New and practical filtering technology* (Beijing: Metallurgical Publishing)
- [4] Evon P, Kartika Amalia and Cerny M2013 *Feasibility study*. 47 33-42
- [5] Jaroslav B, Lucie H and E Thomas 2010 *Conservation and Recycling*. 54 278-282
- [6] Li T, Li J and Liu W Y 2009 *China Water and Wastewater*. 25 66-68
- [7] Krishnamurthy S, and Viraraghanan T 2005 *Energy Sources*.27 113-122
- [8] Zhang N M, Qu Q W and Chen Y H 2015 *Coal Technology*. 34 241-243.