

# Linear Quadratic Regulator Procedure and Symmetric Root Locus Relationship Analysis

Mariela Alexandrova<sup>1</sup>, Nasko Atanasov<sup>2</sup>, Ivan Grigorov<sup>3</sup>, Ivelina Zlateva<sup>4</sup>

Department of Automation, Technical University of Varna, Bulgaria

Corresponding Authors Email: m\_alexandrova@tu-varna.bg

**Abstract**— The present paper is focused on linear quadratic regulator (LQR) synthesis. It is evident that the solution of the problem leads to finding a solution of symmetric root locus (SRL) problem. It is proven and analytical evidences is also presented that by using SRL synthesis method and further application of LQR method guarantees stability, minimum phase and gain margins of the closed loop system. The presented mathematical relationships are further proven with experimental investigation in MATLAB programming environment.

**Keywords**— linear quadratic regulator, minimum phase system, Riccati equation, stability, state space, symmetric root locus.

## I. INTRODUCTION

The scope of the present paper is LQR synthesis in the state space. According to the state feedback control chosen, the synthesis procedure is related to determination of the state feedback matrix elements in a manner that a compromise between achieving the desired settling time and the control effort needed. In the presence of immeasurable states, observers are typically used for state vector estimation. The prerequisites needed for the synthesis are the system to be completely controllable and observable although advanced state variable design techniques can handle situations wherein the system is only stabilizable and detectable. In the present paper it is assumed that the system is completely controllable and observable and all the state variables are measurable.

The procedure for LQR synthesis requires the feedback matrix to be chosen in order to satisfy the condition for minimum value of the cost function presented as integral performance estimation. The closed loop is considered optimal as it guarantees the minimum possible value of the cost function. The synthesis procedure allows the operator to choose the weights so that the compromise between the state cost and the control cost is acceptable. The major disadvantage of this technique is that the exact poles position and the control effort value are initially unknown.

The present paper aims to investigate the relationship between the linear quadratic regulator procedure and the symmetric root locus of the closed loop system.

For the provision of this analysis few main aspects should be investigated in details and further proven:

1. Find analytic solution of the LQR synthesis based on the Pontriagin's minimum principle.
2. Show that LQR synthesis can be solved by SRL.
3. Use SLR procedure to prove that when LQR synthesis is applied the closed loop system will always be stable and minimum phase.

## II. LQR SYNTHESIS BASED ON THE PONTRIAGIN'S MINIMUM PRINCIPLE

For a given closed loop system, denoted in Fig.1, the state space open loop system model is:

$$\begin{aligned}\dot{\mathbf{x}} &= \mathbf{Ax} + \mathbf{Bu} \\ \mathbf{y} &= \mathbf{Cx}\end{aligned}\tag{1}$$

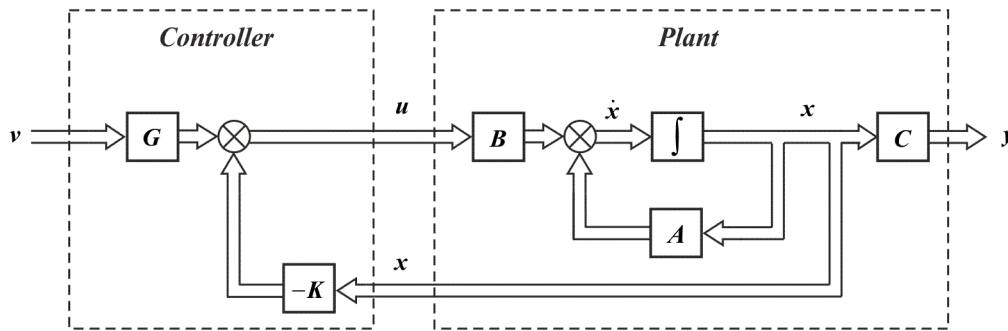

FIGURE 1. CLOSED LOOP BLOCK DIAGRAM

The feedback control law in the presence of a reference signal is:

$$u(t) = -Kx(t) + Gv(t) \tag{2}$$

where  $v(t)$  is the reference value and the matrix  $G$  is given an auxiliary function to recalculate the reference value for steady state error free system [1]. Assuming the following transformation  $v(t) = 0 \Leftrightarrow t > 0$  the control design problem is known as regulator problem [2]. It has the following aspects: determination of  $K$  so that all initial conditions are derived to zero using a specified approach determined by the desired system performance which corresponds to the closed loop pole values.

The optimal control design (Fig.1) is a constrained optimization problem with cost function  $J(x, u, t, t_f)$  which can be expressed as:

$$J = \frac{1}{2} x^T(t_f) S x(t_f) + \int_0^{t_f} \left( \frac{1}{2} x^T Q x + \frac{1}{2} u^T R u \right) dt \tag{3}$$

and the constrain given by equation (1) [4,6,7]. The matrices in (3) must satisfy  $S \geq 0$ ,  $Q \geq 0$  and  $R > 0$ . The implementation of co-state vector  $\lambda$  [5] consisted of the Lagrange multipliers transforms (3) into unconstrained optimization problem, described by:

$$J = \frac{1}{2} x^T(t_f) S x(t_f) + \int_0^{t_f} \left[ \frac{1}{2} x^T Q x + \frac{1}{2} u^T R u + \lambda^T (Ax + Bu - \dot{x}) \right] dt \tag{4}$$

In order to obtain the minimum value of (4) all the derivatives of  $J$  with respect to  $x$ ,  $u$  and  $x(t_f)$  must be equal to zero. According to the last operation the closed loop dynamics can be determined by the following simultaneous equations for a given mixed boundary conditions  $x(0) = x_0$  and  $\lambda(t_f) = Sx(t_f)$  [4]:

$$\begin{cases} \dot{x} = Ax + Bu \\ \dot{\lambda} = -Qx - A^T \lambda \\ u = -R^{-1} B^T \lambda \end{cases} \tag{5}$$

This is the so called two point boundary value problem (TPBVP) [8]. The system (5) can be presented as a homogenous vector-matrix differential equation:

$$\begin{bmatrix} \dot{x} \\ \dot{\lambda} \end{bmatrix} = \underbrace{\begin{bmatrix} A & -BR^{-1}B^T \\ -Q & -A^T \end{bmatrix}}_{\mathbf{H}} \begin{bmatrix} x \\ \lambda \end{bmatrix} \tag{6}$$

Where  $\mathbf{H}$  is the so called Hamiltonian matrix [5].

The substitution:

$$\lambda = Px \tag{7}$$

and the equation system (6) leads to the following expression:

$$\dot{\lambda} = \dot{P}x + P\dot{x} = \dot{P}x + PAx - PBR^{-1}B^T Px = -Qx - A^T Px \quad (8)$$

After the reduction of the common multiplier  $x$  equation (8) can be written in the form:

$$\dot{P} = -A^T P - PA - Q + PBR^{-1}B^T P \quad (9)$$

known as differential vector-matrix Riccati equation.

This equation can be solved backward in time under the condition:

$$P(t_f) = S \quad (10)$$

It defines the optimal control law:

$$u(t) = -R^{-1}B^T P(t)x(t) = -K(t)x(t) \quad (11)$$

The steady state value of equation (11) is the solution of the algebraic Riccati equation:

$$A^T P + PA + Q - PBR^{-1}B^T P = 0 \quad (12)$$

and determines the control law in the form:

$$u(t) = -R^{-1}B^T Px(t) = -Kx(t) \quad (13)$$

### III. LQR SYNTHESIS AND SRL

The closed loop system dynamics is described by the equation (6). The eigenvalues of matrix  $H$  are the closed loop poles. They are doubled in number than the number of the eigenvalues of matrix  $A$  and can be further determined as a solution of the following equation:

$$\det(sI - H) = 0 \quad (14)$$

The implication of the substitution  $Q = C^T C$  and introduction of the following notations are further used for the purpose of this analysis:

$$W_p(s) = C(sI - A)^{-1} B \quad (15)$$

$$W_p^T(-s) = B^T (-sI - A^T)^{-1} C^T \quad (16)$$

$$D(s) = \det(sI - A) \quad (17)$$

According to some well known matrix relations and transformations described in [7] the equation given below can be obtained:

$$\det(sI - H) = (-1)^n D(s)D(-s) \det[I + R^{-1}W_p^T(-s)W_p(s)] \quad (18)$$

where  $n$  is the state vector dimension.

For SISO system equation (18) can be presented as:

$$\det(sI - H) = (-1)^n D(s)D(-s)[1 + R^{-1}W_p(s)W_p(-s)] = 0 \quad (19)$$

The open loop system transfer function could be then described as a polynomial ratio:

$$W_p(s) = C(sI - A)^{-1} B = \frac{N(s)}{D(s)} \quad (20)$$

Considering (20) equation (19) is transformed into:

$$\det(s\mathbf{I} - \mathbf{H}) = (-1)^n [D(s)D(-s) + R^{-1}N(s)N(-s)] = 0 \quad (21)$$

Consequently the closed loop poles determination can be solved as standard root locus problem with variation of  $R^{-1}$  into the range  $(0, \infty)$ . The specifics here are that the locus is symmetric in accordance with the abscissa as well as with the ordinate and has  $2n$  loci. Half of them are positioned in the left half of the complex plane and are related to the  $n$  stable closed loop poles corresponding to the state vector  $\mathbf{x}$ . The other half of loci are in the right half plane and are related to the  $n$  unstable closed loop poles which correspond to the co-state vector  $\lambda$ . The unstable poles can be transformed into stable if the differential Riccati equation is solved backward in time [7,8].

#### IV. STABLE AND MINIMUM-PHASE CLOSED LOOP SYSTEM

As it was described above the weight matrices must be  $\mathbf{Q} \geq 0$  and  $\mathbf{R} > 0$ . It is also known that only the state cost weight can be equal to zero. Thus according to the root locus it is more convenient weight factor  $\rho$  to be implemented under the assumption of  $R = 1$  [2]. The cost function can be then described by the following integral relation:

$$J = \frac{1}{2} \int_0^{\infty} \rho \mathbf{x}^T \mathbf{Q} \mathbf{x} + \mathbf{u}^T \mathbf{u} dt \Leftrightarrow = \frac{1}{2} \int_0^{\infty} \rho \mathbf{y}^T \mathbf{y} + \mathbf{u}^T \mathbf{u} dt \quad (22)$$

The SRL is determined by the equation [6]:

$$D(s)D(-s) + \rho N(s)N(-s) = 0 \quad (23)$$

and is expressed as a function of the weight factor  $\rho$  which varies into the range  $[0, \infty)$ .

For  $\rho = 0$  minimum settling time is not a requirement. The stable closed loop poles coincide with the system roots in the left half plane and/or with the reflection of the unstable open loop poles in accordance with ordinate. Thus the closed loop system stability is guaranteed with lower values of the control signal.

For higher values of  $\rho$  the poles are shifted following the root loci and respectively the control effort increases too.

For  $\rho \rightarrow \infty$ ,  $m$  closed loop poles approaching open loop zeros in the left half plane and/or their reflection in the right half plane. In this so described case the impact of those poles and zeros is negligible. The rest  $(n - m)$  poles approaching infinity following specific trajectories and form the so called Butterworth pattern. The settling time is shortest possible however the control effort rises dramatically which in some cases is unacceptable [2,8].

The solution of the following equation is investigated in order to confirm those statements:

$$\Delta(s) = D(s)D(-s) + \rho N(s)N(-s) = 0 \quad (24)$$

with variations of  $\rho$  within the range  $[0, \infty)$ . In accordance with the below polynomial form:

$$D(s) = s^n + d_1 s^{n-1} + \dots + d_n \quad (25)$$

and

$$N(s) = n_0 s^m + n_1 s^{m-1} + \dots + n_m = n_0 N_1(s) \quad (26)$$

is obvious that:

$$N(s)N(-s) = n_0^2 N_1(s)N_1(-s) \quad (27)$$

For  $\rho = 0$ :

$$\Delta(s) = D(s)D(-s) = 0 \quad (28)$$

Thus the roots of  $\Delta(s)$ , which are closed loop poles, coincide with the open loop poles and their ordinate symmetric reflections.

For  $\rho \rightarrow \infty$  the first addend in equation (24)  $D(s)D(-s)$  is neglected:

$$\Delta(s) = \rho N(s)N(-s) = \rho n_0^2 N_1(s)N_1(-s) = 0 \quad (29)$$

The polynomial  $\Delta(s)$  is sum of the two addends  $D(s)D(-s)$  and  $\rho n_0^2 N_1(s)N_1(-s)$ . Since the zeros of  $N_1(s)N_1(-s)$  result in zero sum and zero second addend as well then they respectively zero the first addend too. Consequently it can be presented as:

$$D(s)D(-s) = N_1(s)N_1(-s)D_1(s)D_1(-s) \quad (30)$$

and  $\Delta(s)$  is further transformed into the equation:

$$\begin{aligned} \Delta(s) &= N_1(s)N_1(-s)D_1(s)D_1(-s) + \rho n_0^2 N_1(s)N_1(-s) = \\ &= \underbrace{N_1(s)N_1(-s)}_{\Delta_1(s)} \underbrace{[D_1(s)D_1(-s) + \rho n_0^2]}_{\Delta_2(s)} = 0 \end{aligned} \quad (31)$$

The first multiplier  $\Delta_1(s)$  roots are the zeros of the open loop system and their symmetric ordinate reflections. The second multiplier:

$$\Delta_2(s) = D_1(s)D_1(-s) + \rho n_0^2 \quad (32)$$

can be transformed as follows:

$$\Delta_2(s) = (-1)^{n-m} s^{2(n-m)} + \tilde{d}_1 s^{2(n-m)-1} + \tilde{d}_2 s^{2(n-m)-2} + \dots + \tilde{d}_{2(n-m)} + \rho n_0^2 \quad (33)$$

For  $\rho \rightarrow \infty$  the roots of  $\Delta_2(s)$  converge to the roots of equation:

$$(-1)^{n-m} s^{2(n-m)} + \rho n_0^2 = 0 \quad (34)$$

Respectively the roots of  $\Delta_2(s)$  converge to the roots of the binomial equation:

$$s^{2(n-m)} + \frac{1}{(-1)^{n-m}} \rho n_0^2 = 0 \quad (35)$$

The roots of equation (35) appear to be the apexes of regular  $(2(n-m))$ - dimensional polygon and are positioned on the circle centered in the origin with radius  $(\rho n_0^2)^{1/2(n-m)}$ . For higher values of  $\rho$  they are shifted from the origin following the trajectories by the circle radiuses forming equal angles  $\left(\frac{\pi}{n-m}\right)$ . The resulted plot with  $(2(n-m))$  rays is associated with the so called Butterworth pattern [1,2,3].

## V. NUMERICAL EXAMPLE

The open loop system investigated is unstable and non minimum-phase described by the below presented transfer function [4]:

$$W(s) = \frac{(s-2)(s-4)}{s^2(s-1)(s-3)(s^2+0.8s+4.16)}$$

The problem formulated is LQR synthesis aiming to minimize the value of the cost function  $J$  (22).

Specific algorithm has been developed in MATLAB for the purpose of this analysis. The resulted SRL is shown in Fig.2.

It is evident that:

- for  $\rho=0$  two of the SRL loci begin at the two stable complex roots of the open loop system  $s_{1,2} = -4 \pm 2i$ . Another pair loci begin at zero pair roots  $s_{3,4} = 0$  and third pair begin at the ordinate symmetric unstable roots  $s_5 = 1$  and  $s_6 = 3$ . The analysis shows that in this case in particular the closed loop system is at least considered stable;
- with the increase of the value of  $\rho$  the last pair loci described above are approaching the ordinate symmetric positive zeros  $s = 2$  and  $s = 4$ ; when  $\rho$  approaches infinity that pair ends at those zeros which leads to compensation of the influence of the zeros  $s = -2$  and  $s = -4$  with two of the poles. The rest four loci are shifting from the origin following the radiuses of central circle, forming equal angles of  $\pi/4$ . The result is retention of the closed loop system stability, short settling time, and increase in the natural system frequency; however the system requires higher control signal values.

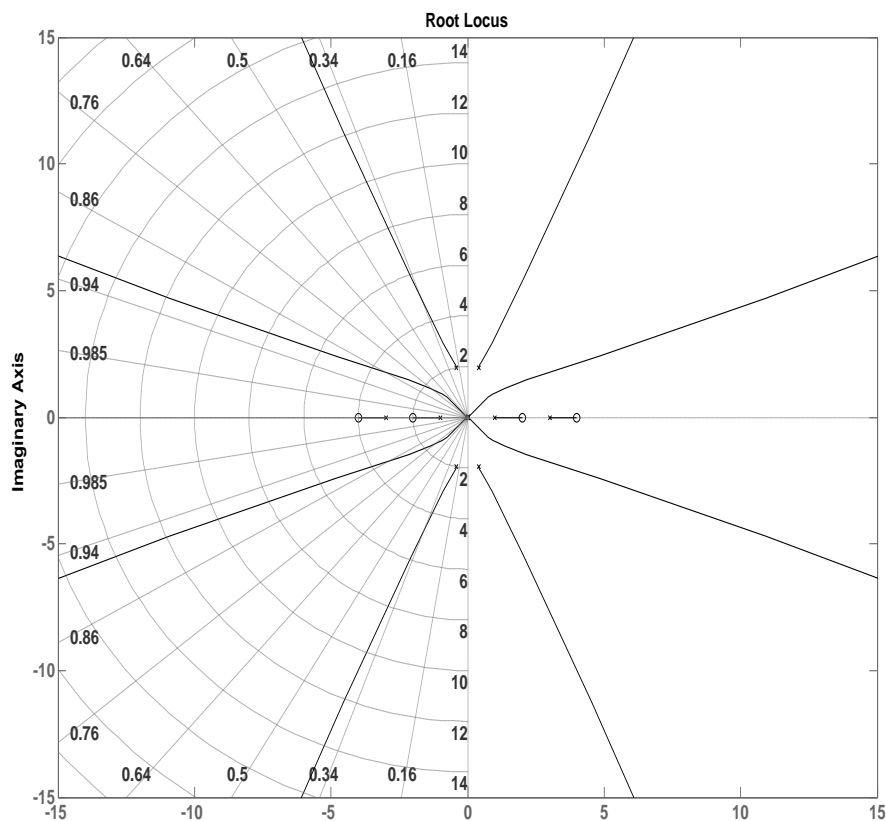

FIGURE 2. BUTTERWORTH MODEL FOR SRL

## VI. CONCLUSION

The paper presents analytical evidence that LQR synthesis can be considered as SRL problem.

In the presence of evidence for completely controllable and observable (stabilizable and detectable) open loop system the state feedback synthesis is invariant in accordance with open loop system stability.

LQR can be also taken into consideration as a method for state feedback matrix generation with guarantees for stability, minimum phase and stability margins of the closed loop system.

This type of analysis, using graphic interpretation (*ex. Fig.2*) allows direct identification of the damping ratio and corresponding natural frequencies  $\omega_n$  and respectively further calculation of the weight coefficient  $\rho = \omega_n^{2(n-m)}$  for any point positioned on the loci.

The results delivered give further option for investigation of possible relationship and application of the pole placement synthesis and LQR synthesis based on SRL in the frequency domain.

### ACKNOWLEDGEMENT

This paper is developed in the frames of the project ПД1 "Investigation of Algorithms for Parameter Estimation in Self-Tuning Controllers", ДН971-ПД/09.05.2017 and project НП6 "Research and Synthesis of Algorithms and Systems for Adaptive Observation, Filtration and Control", ДН997-НП/09.05.2017.

### REFERENCES

- [1] Atanasov, N. and A.Ichtev, K.Ishtev (2012). Control Theory Part 1, Technical University of Varna, Bulgaria.
- [2] Dorf, R. and R.Bishop (2008). Modern Control Systems, Eleventh edition, Pearson Prentice Hall.
- [3] Franklin, G.F. and J.D.Powell, A.Emami-Naeini (2006). Feedback Control Of Dynamic Systems, Fifth Edition, Pearson Prentice Hall.
- [4] How, J. (2001). Feedback Control Systems, <http://hdl.handle.net/1721.1/45531>.
- [5] Kurtal, P. (2013). Dynamic Optimization in Continuous Time, Lecture notes (Econ210), <https://web.stanford.edu/~pkurlat/teaching/14%20-%20Continuous%20Time.pdf>.
- [6] Perry, Y.Li (2017). Advanced Control Systems Design, ME8281, Lecture notes, [http://www.me.umn.edu/courses/me8281/notes/LQ\\_Abiram.pdf](http://www.me.umn.edu/courses/me8281/notes/LQ_Abiram.pdf), 156-179.
- [7] M Plett, G. (2017). Multivariable Control Systems II, ECE5530, Lecture notes, <http://mocha-java.uccs.edu/ECE5530/index.html>, 3-1 – 3-37.
- [8] Shahian, B. and M.Hassul (1993). Control System Design Using Matlab, Prentice-Hall Inc., New Jersey.