

Performance of FACTS Devices in the Improvement of Power Quality

Kavita Mhaskar¹, Chitrlekha Vangala²

Department of Electrical Engineering, Mumbai University, Mumbai

Abstract—This paper presents an analysis of implementation of Flexible AC Transmission System (FACTS) devices for maintaining Power Factor. The electrical loads include induction motor driven equipments, which consume reactive power, increase the amount of apparent power in the distribution system, which is important because a low power factor can waste energy, and results in inefficient use of electrical power and often result in higher energy bills. The improvement of Power Factor as close as unity is very essential in the industry as well as domestic electric appliances, due to increase in power demand. The Power factor maintenance provides increase in system efficiency. The solution for power factor unity is done with FACTS devices, which has the manageable capacity. The possibility of low power factor increases with inductive load in nature. Hence, the need of unity in power factor is very significant. **Keywords**—voltage source convertor, FACTS device, STATCOM, voltage sag and swell.

Keywords: FACTS, Power Factor Correction, Power Factor Improvement.

I. INTRODUCTION

One Modern society relies increasingly on electrical power, requiring higher demands of power stability and power quality. Maintaining power quality is an important factor in the power system development and improvement. The term unity in power factor plays a vital role mostly in the industrial sector. The Power factor correction is very essential in industries due to presence of electrical loads. Power loss is due to poor power factor in the distribution system with more inductive loads. The purpose of power factor correction is due to lag in reactive power with inductive loads. Traditionally, the reactive power can be compensated by:

- Generator excitation regulation.
- Reconfiguration of system structure.
- Synchronous compensator.
- Change of voltage by transformer tap to adjust the power flow in the grid (OLTC).
- Series compensation capacitor.
- Switching in/out of the shunt reactor or shunt capacitor.
- Magnetic controlled reactor

The ratio of active power to the resultant power, called power factor, implies that because of greater demand for reactive power, the percentage of useful utilization of the total generated power starts diminishing. Power factor states that the percentage of consumed power (KW) versus supplied power (KVA).

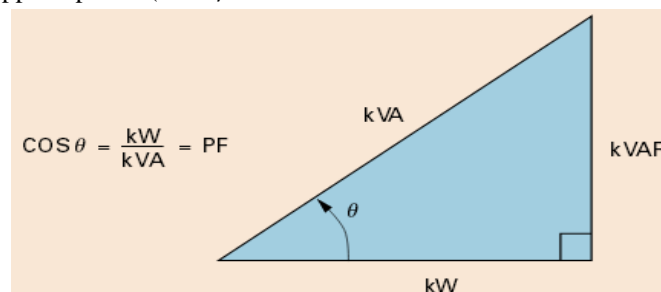

Fig.1 Structure of Power Triangle

This is important because a low power factor can waste energy, result in inefficient use of electrical power, and often result in higher energy bills.

II. FLEXIBLE AC TRANSMISSION SYSTEM (FACTS) DEVICES

FACTS are an emerging technology and its principle role is to enhance the controllability and power transfer capability in AC systems. It gives a new opportunity in controlling and enhancing the power system. It is used for the AC transmission of electrical energy due to static and it is generally power electronics based device. The amount of transferring power from the sending end to the receiving end is limited by the operating parameters of the transmission line such as line impedance, phase angle between the sending and receiving voltages and the magnitude of the voltages. The transferable power can be increased by one of the four compensation methods. These methods are generally implemented by switching power electronics together with appropriate control strategy, these compensators are known as FACTS controllers. The term "FACTS" covers several power electronics based systems used for AC power transmission. For the nature of power electronics equipment, FACTS solutions will be particularly justifiable in applications requiring one or more of the following qualities: -Rapid dynamic response -Ability for frequent variations in output -Smoothly adjustable output.

2.1 Basic types of FACTS Controllers

The FACTS controllers are classified as,

Series Controllers

Shunt Controllers

Combined Series-Series Controllers

Combined Series-Shunt Controllers

1. Series Controllers:

It could be variable impedance (capacitor, reactor, etc) or a power electronic based variable source of main frequency, sub-synchronous and harmonic frequencies to serve the desired need.

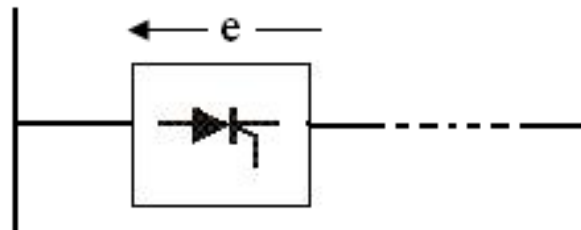

Fig.2 Structure of Series Controllers

- Inject a voltage in series with the line.
- If the voltage is in phase quadrature with the current, controller supplies or consumes reactive power.
- Any other phase, involves control of both active and reactive power.

2. Shunt Controllers:

- It could be variable impedance (capacitor, reactor, etc) or a power electronic based variable source or combination of both.

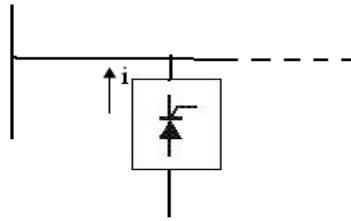

Fig. 3 Structure of Shunt Controllers

- Inject a current in the system.
- If the current is in phase quadrature with the voltage, controller supplies or consumes reactive power.
- Any other phase, involves control of both active and reactive power.

3. Combined Series-Series Controllers:

- It could be a combination of separate series controllers or unified controller.

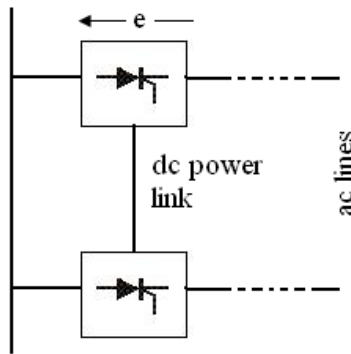

Fig.4 Structure of Combined Series-Series Controllers

- Series controllers supply reactive power for each line and real power among lines via power link.
- Interline power flow controller balance real and reactive power flow in the lines.

4. Combined Series-Shunt Controllers:

- It could be a combination of separate series & shunt controllers or unified power flow controller.

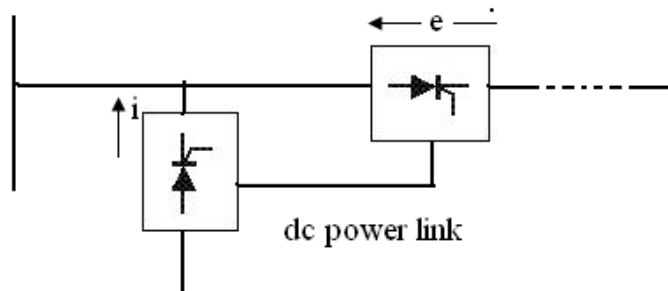

Fig.5 Structure of Combined Series-Shunt Controllers

- Inject current into the system with the shunt controller and voltage in series with the line with series controller.
- When the controllers are unified, exchange real power between series and shunt controllers via power link.

Choice of the controller:

- Series controller controls the current/power flow by controlling the driving voltage.
- To control current/power flow and damp oscillations, series controller is several times more powerful than shunt controller.
- Shunt controller injects current in the line
- Thus it is used for more effective voltage control & damp voltage oscillations.
- Injecting the voltage in series with the line can improve the voltage profile.
- But shunt controller is more effective to improve the voltage profile at substation bus.
- For a given MVA, size of series controller is small compared to shunt controller.
- Shunt controllers cannot control the power flow in the lines.
- Series controllers should bypass short circuit currents and handle dynamic overloads.
- Controllers with gate turn off devices are based on dc to ac converters and exchange active/reactive power with ac lines.
- This requires energy storage device.
- Energy storage systems are needed when active power is involved in the power flow.
- A controller with storage is more effective for controlling the system dynamics.

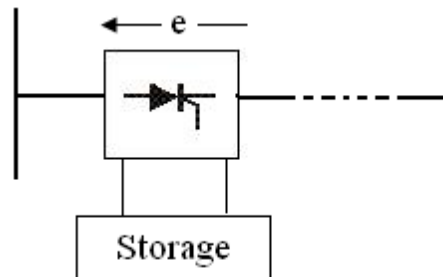

Figure 6: Structure of Controller with Storage Device

A converter-based controller can be designed with high pulse order or pulse width modulation to reduce the low order harmonic generation to a very low level. • A converter can be designed to generate the correct waveform in order to act as an active filter.

2.2 Benefits of FACTS devices

The FACTS devices involve some of the benefits, where the devices are used in reducing the need for construction of new transmission lines, capacitors and reactors. It provides greater ability to transfer power between controlled areas, which also help to damp the power oscillations that could damage the equipment. The transient stability of the system can be improved. It also controls real and reactive power flow in the line independently and damping of oscillations which can threaten security or limit the usable line capacity.

Some of the other possible benefits are,

1. Increase in quality of supply for sensitive industries.
2. Increase in transmission system reliability and availability.
3. Better utilization of existing transmission system assets.
4. Provide greater flexibility in new generation.
5. Reduce reactive power flows, thus allowing the lines to carry more power that is active.
6. Reduce loop flows.

III. IMPACT OF FACTS IN INTERCONNECTED NETWORKS

The benefits of power system interconnection are well established. It enables the participating parties to share the benefits of large power systems, such as optimization of power generation, utilization of differences in load profiles and pooling of reserve capacity. From this follows not only technical and economical benefits, but also environmental, when for example surplus of clean hydro resources from one region can help to replace polluting fossil fuelled generation in another. For interconnections to serve their purpose, however, available transmission links must be powerful enough to safely transmit the amounts of power intended. If this is not the case, from a purely technical point of view it can always be remedied by building additional lines in parallel with the existing, or by up rating the existing system(s) to a higher voltage. This, however, is expensive, time consuming, and calls for elaborate procedures for gaining the necessary permits. In addition, in many cases, environmental considerations, popular opinion or other impediments will render the building of new lines as well as up rating to ultrahigh system voltages impossible in practice. This is where FACTS comes in.

IV. CONCLUSION

Power Factor is the most significant part in the utility areas. FACTS devices are preferred for improving the stability of power system. It is possible to use these devices for the control flows of active and reactive power. It also contributes to improve the limits of static, transient stability and voltage quality. Hence, as efficiency increases, the production of the plant also increases. Where, the cost of electric bills also be reduced. This is economic to correct dynamic power factor in big industries. Thus, these are powerful devices that aid in the improvement of power system stability, hence it is concluded that these devices are given more priority to maintain the stability in power systems.

REFERENCES

- [1] Aparna Sarkar, Umesh Hiwase, "Automatic Power Factor Correction by Continuous Monitoring," International Journal of Engineering and Innovative Technology, Volume (4) Issue (10), pp. 170-176, 2015.
- [2] Amol P. Patil, Prof. P.V. Baviskar, "Implementation of Static VAR Compensator (SVC) for Power Factor Improvement," International Journal of Emerging Technology and Advanced Engineering, Volume (5) Issue (5), pp. 368-372, 2015.
- [3] Praveen V.A, Sumaya Fathima, Sumalata I.A, Badiger K.D, Kandagal S.S, "Automatic Power Factor Correction using Capacitor Banks and 8051 Microcontroller," International Journal of Engineering and Technical Research, Volume (3) Issue (6), pp. 163-167, 2015.
- [4] Muhammed H. Rashid, Power Electronics Circuits, Devices, and Applications, Pearson Education Inc, India, 2004.
- [5] Dr.P.S.Bimbhra, Power Electronics, Khanna Publishers, New Delhi, 2011.
- [6] V.C. Eugin Martin Raj and S. Lese, "A Novel Approach for Power Factor Correction using Microcontroller in Domestic Loads," Middle-East Journal of Scientific Research, Volume (24) Issue (4), pp. 1042-1046, 2016.
- [7] S.N.Singh, Electric Power Generation, Transmission and Distribution, Prentice-Hall of India Private Limited, New Delhi, 2006.
- [8] G.Premkumar, B.Muthukumar, "Design, Fabrication and Implementation of Microcontroller Controlled Static Var Compensator", International Journal of Computer Applications, Volume (81) Issue (19), pp. 43-50, 2013.
- [9] "Power Factor Correction: A Guide for the Plant Engineer," Eaton, United States, 2014.
- [10] "Power Factor Correction and Harmonic Filtering in Electrical Plants," ABB, Italy, 2008.
- [11] Nang Sabai, Hnin Nandar Maung, and Thida Win, "Voltage Control and Dynamic Performance of Power Transmission System using Static Var Compensator", World Academy of Science, Engineering and Technology, Volume (44), pp.455, 2008.
- [12] Alisha Banga and S.S.Kaushik "Modelling and Simulation of SVC Controller for Enhancement of Power System Stability", International Journal of Advances in Engineering & Technology, Volume (1), Issue (3), pp.79-84, 2011.
- [13] Abdelaziz Chaghi, Ahmed Louchene and Rafik Bensaadi, "A Microcontroller-based Static Var Compensator for Unbalanced Loads", In the Proceedings of 19th International Conference on Electricity Distribution, pp.1-4, 2007.
- [14] Roberto Alves, Miguel Montilla, Ernesto Mora, "Increase of Voltage Stability and Power Limits using a Static Var Compensator", Renewable Energy & Power Quality Journal, No.1, 2003.
- [15] Laszlo Gyugyi, "Power Electronics in Electric Utilities: Static Var Compensators", In Proceedings of IEEE, Vol 76, No 4, 1988.
- [16] Musthafa.P, M.Sivasubramanian, K.Sakthidhasam, "Analysis of Dynamic Power Factor Correction using Flexible AC Transmission Systems", International Journal of Engineering Research and Applications, Vol 1, Issue 3, pp710-715, 2011.



7th National Conference on
"Role of Engineers in Nation Building" organized by VIVA Institute of Technology, Mumbai
(1st and 2nd March 2019)

International Journal of Engineering Research & Science (IJOER)

ISBN: [978-93-5321-411-1]

ISSN: [2395-6992]

[Vol-5, Issue-3, March- 2019]

- [17] Modelling of SVC in Power System Studies, ABB Company Manual, Information NR 500- 026E, Sweden, 1996.
- [18] "Solutions for Static Var Compensator", NR Electric Co., Company Manual, 2012.
- [19] M.Karthikeyan and G.Rajalakshmi, "Expert (Fuzzy Logic) System Approach for Better Power Distribution," International Journal of Innovative Science, Engineering & Technology, Volume (3) Issue (4), pp. 67-75, 2016