

## Automated Coffee Vending Machine Using RFID

Darsh Bhatt<sup>1</sup>, Mahesh Bhandari<sup>2</sup>, Salman Khan<sup>3</sup>, Chinmay Pingulkar<sup>4</sup>

Department of Mechanical, VIVA Institute of Technology, Mumbai-66

**Abstract**— The vending machine are usually used for fast and instant service. These systems used in this are mostly of automation were coin or tags are used for identification. This paper presents system which work on RFID Tags , it operates on RFID system. This system gives information regarding access of RFID. A RFID reader scan the respective tags. For identification particular RFID tag is given to each employee. According to program the numbers of cups per day as per employee requirement are programmed on Arduino chip. Then an employee goes to vending machine show his card to the reader then the drink is released. For every single cup of coffee the record will be feed in arduino.

**Keywords**— Arduino, RFID, Vending machine, Timer sensor, Heating Coil.

### I. INTRODUCTION

Vending machine is a machine that releases item components or item whenever required after ensuring to customer automatically. These machines are mostly used in various area like commercial, industrial, shops, organization etc. Automatic regular coffee vending machine including coffee powder, sugar, and milk powder stored in container. It also includes the hot water container where the water is heated through heating coil. After giving command through a program the machine add that specific amount of ingredients in the hot water. And then it gets released in the cup through nozzle opening. The controlling like heating and mixing of ingredient is done by the use of microcontroller.

### II. PROBLEM DEFINITION

The installation of approximately Coffee Vending machines in an college space for mechanical faculty, saved one of 45% of total cost spend on coffee. Many of the staff are happy with the concept of having control over their coffee, from having the machine availability of having the ability to choose how many spoon of each ingredient is dispensed. Powder milk has the tendency to lump when the machine is not thoroughly cleaned. This can cause quite a lot of frustration for staff without a full time cleaning person.

Control means everyone doesn't get what they want – Coffee vending machines control how much product people can dispense from them which often contributes to their cost saving effect. Control on the flipside can lead to unhappy staff members who can't use as much milk and sugar as they want once a vending machine has been installed.

### III. PROPOSED METHODOLOGY

In traditional approach wherever the coffee vending machine is placed or installed, man need to be physically present there to serve the coffee and to continuously monitor the system. But sometimes it is not possible for man to be physically present there. This proposed system is designed in such a way that a customer can order his coffee via a mobile app. It provides complete authentication of the customer using RFID (Radio frequency identification) reader.

It consists of the PIC18F877A microcontroller, temperature sensor LM35, water level BC547 sensor, RFID reader, 16\*2 LCD display, Wi-Fi module ESP8266, relay driver ULN2803 where PIC16F877A is a master controller and all rest parts are interfaced with it. Here the relay driver is used to give a start to coffee heater, coffee selector and the pump.

The level of the ingredient in the machine is continuously monitored by the sensor. Microcontroller PIC18F877A is used to read the data from the sensor. The temperature sensor will maintain the constant water temperature. In this project a PIC microcontroller reads data from the RFID reader. The RFID reader sends 12 bytes of data at 9600 baud rate. The

microcontroller displays this data on LCD screen and sends the data to the Wi-Fi module ESP8266. The data is sent to the Wi-Fi module at 9600 baud rate. The ESP 8266 module uses AT commands to send the data. The data is sent to the cloud. The cloud receives data in Coffee Vend channel. An android app is used to read data from the Thing speak cloud. The android APP uses Read API key to read data from Thing speak channel. Then android app receives data from the channel and displays in the text window. Then we must click on Prepare Coffee button on the app. The app sends data on cloud. The microcontroller receives the data from the cloud and starts the procedure. The microcontroller first checks if water in the tank is available or not. It displays Water Level Low message and waits until sufficient water level is reached. Then it starts the heater and when the temperature reaches 70 degree it stops the heater. Then it adds 1 spoon of coffee mixture in heated water with the help of dispenser. Next it pumps the ready coffee to the cup by a 12V Dc pump.

#### KEY PARTS:-

- **RFID: Radio Frequency Identification**

Radio Frequency Identification is an electronic component which consists of a small chip . The chip can manage a data of about 2000 bytes. RFID is alike to the barcode which provides a exclusive identifier for that object. RFID device is scanned to retrieve the information. RFID tag is scanned and identified by means of Unique Identification Number (UIN) by the RFID reader and it is not essential that the RFID tag should be in the sequence to a reader. The RFID reader is able of scanning the RFID tag if it is within the range of area of the system. The reader consists of a RF module which act as the transmitter and receiver for the radio signals. The transmitter itself is a combination of oscillator, modulator and an amplifier.

The modulator impinge the data command upon the carrier signal created oscillator. The boosting of the signal is amplified so that taken the signal can awake the tag and tag reader. The microprocessor or microcontroller stores the data and it is the control unit which employs an operating system and memory or data. The RFID reader installed in this system..

- **Arduino Uno Controller**

It is 8bit microcontroller which is based on the AVR enhanced RISC architecture. It is usually based on 32kbytes flash program memory and 1Keprom. Arduino consists of both a physical programmable circuit board (often referred to as a microcontroller or ) and a respective software, or IDE (Integrated Development Environment) that run your computer, used to write and upload computer code to the physical board. There is no requirement of separate piece of hardware (called a programmer) in order to encode onto the board Arduino can correlate with buttons, LEDs, switches, motors, speakers, GPS units,.

- **IR Sensor**

A proximity sensor help out to auto detect any object without any contact. It mainly consists of two parts. One of these is transmitter i.e. LED, and another is receiver i.e. detector. The IR sensor is interfaced and connected with the Arduino board. It is used to detect the availability of the cup for the coffee. The required power supply for the IR sensor is the 5 Volt.

- **AC Motor**

The AC motor is used to control the feed material like coffee powder, milk and mixture. By linking the shaft of motor to the hopper mechanism the flow of solid material can be managed. The controller is programmed in such a way that the motor will dispatched amount of ingredients on respective time. The power supply required to run motor is 230 Volts, 50Hz. It is controlled through the relay board or circuit.

- **LCD Display**

A liquid Crystal Display is a flat display use for indication of process being performed within the system. LCDs are used to display subjective images ( as in general purpose computer display ) or fixed images which can be display or hidden such as preset words. The lcd display is use to display the information regarding the consumer (such as Name, Unique ID, references etc ).

- **POWER SUPPLY**

Since Arduino (ATMega 328P), LCD, IR operate on 5Volt DC Supply, we have used 7805 regulator IC and 0.05 micro farad capacitor that generate conatant output voltage 5Volt, output current capability of 100 mA. To run the AC motor and heater we require 230 Volt, 50 Hz supply.

#### IV. BLOCK DIAGRAM OF THE PROPOSED SYSTEM

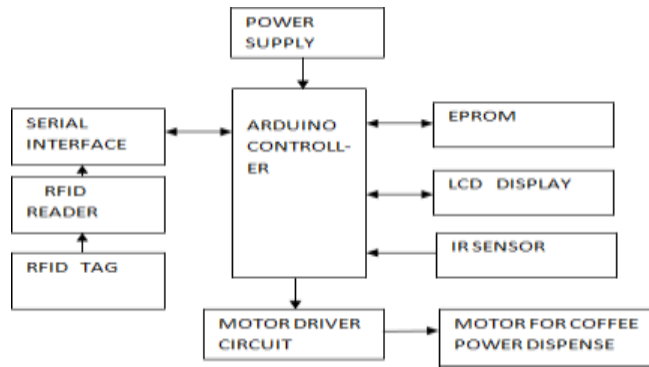

Fig 3.1: Block Diagram of proposed system

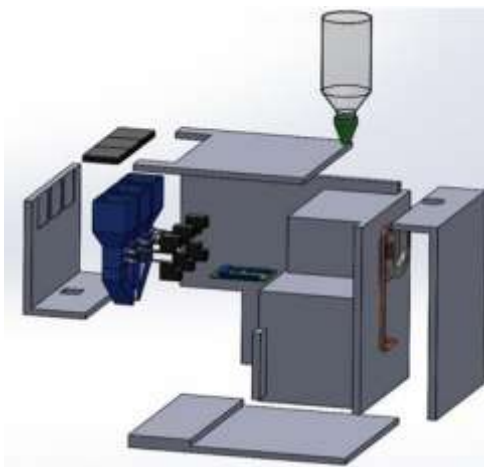

Fig.4.1 3D Model



Fig.4.2 Arduino Uno Chip & RFID Tag



Fig.4.3 Heating Coil



Fig.4.4 Plastic Container

## V. CONCLUSION

This project aim is on automatic coffee vending machine using the arduino controller and RFID technology which is used to control the consumption of coffee with the least lead time and also reduce the waste of product in low budget and also gives the historical data in arduino uno-chip. The proposed system is the design of prototype model for an automatic vending machine. The controller part was tested and it was found that automatic vending machine prototype was working according to the specifications for which it was designed. The prototype model was designed for the implementation of the mechanical structure of a vending machine which finally results in vending a item upon the insertion of the coin. Implementation of this machine in schools and colleges will help the students to take the items whenever they are in need of it. Coins were inserted and items were vended successfully. In future, vending machines of maximum accuracy and efficiency can be achieved with better design and faster control equipment's.

## REFERENCES

- [1] Asmita Bodhale, JS Kulkarni, "Arduino Based Vending Machine," International Journal of Engineering Technology, Management and Applied Sciences., vol.5 , no. 5, pp.795-800, 2017.
- [2] Sunil Kumar, Richa Pandey, "DESIGN OF A SIMPLE VENDING MACHINE USING RADIO FREQUENCY IDENTIFICATION (RF-ID)," ELK asian pacific journal,special issue, ISBN-978-81-9304, 2016, pp.1-4.
- [3] Marta Mesías, Francisco J.Morales, "Acrylamide in coffee: Estimation of exposure from vending machines,"Journal of Food Composition and Analysis., Vol. 48, Pages 8-12, 2016.
- [4] Pieter Koopman, Rinus Plasmeijer, "Fully automatic testing with functions as specifications," in Central European Functional Programming School., 2014, pp. 35-61.
- [5] Kwangsoo Kim, Dong-Hwan Park, Hyochan Bang,"Smart coffee vending machine using sensor and actuator networks," in Consumer Electronics (ICCE) IEEE International Conference on., 2014, pp. 71-72.
- [6] N. Jazdi," Cyber physical systems in the context of Industry 4.0" in IEEE International Conference on Automation, Quality and Testing, Robotics. , 2014, pp. 543-547.
- [7] VVS Vijay Krishna, A Monisha, Sk Sadulla, J Prathiba, "Design and implementation of an automatic beverages vending machine and its performance evaluation using Xilinx ISE and Cadence," in Fourth International Conference on Computing, Communications and Networking Technologies (ICCCNT)., 2013, pp. 1-6