

## Developing cost-effective Dot Matrix Braille Printer

Happyraj Yadav<sup>1</sup>, Sai Ghawali<sup>2</sup>, Sharad Gaikwad<sup>3</sup>, Mayur Rane<sup>4</sup>

Department of EXTC, Mumbai University, Mumbai

**Abstract**— There are large numbers of partially and completely visually disabled persons in our country. Their integration as a productive and capable member of society is hampered as they could not get a proper education. This project will help a visually disabled and blind student to learn the Braille language to overcome the illiteracy. With the help of this project in the educational bodies, teacher can translate the text into the Braille language. The input to the braille printer is given as text and this can be translated into Braille language so that a visually disabled persons able to learn the Braille language.

**Keywords**— Braille language, Visually disabled and blind student, six raised dots, Bluetooth module, literacy rate.

### I. INTRODUCTION

The Braille system is a method of writing things. It is invented by the French man, Louis Braille. The system is used by visually impaired and blind people to read and write. The Braille system uses a set of raised dots that can be felt with fingers. These are set of dots representing alphabets, numbers and some punctuation[1].

•	• •	••	•• •	• •	•• •	•• ••	•• •	• •	•• •
a	b	c	d	e	f	g	h	i	j
• •	• • •	•• •	•• ••	• •	•• •	•• •• •	•• ••	• •	•• ••
k	l	m	n	o	p	q	r	s	t
• ••	• • ••	•• ••	•• ••	• •	•• ••				
u	v	x	y	z	w				

**Fig.1 Dot Matrix Pattern[2]**

He invented a system which allowed them to read and write sentences and to do mathematics. Later he started a school for blind children. His writing system used two columns which had between one and six positions each. Braille uses cells of six raised dots, in two columns of three dots each. The dot positions on the left are numbered one, to three, the ones on the right four to six, as shown in the fig.no1. Each character is coded with certain dots present, and others absent. Trained Braille readers can read nearly 100 words per minute, trained braille readers who do not have sight problems can get to about 250 to 300 words per minute. A Braille printer is an impact device that creates tactile dots on heavy paper, making written documents accessible to blind individuals [1,2].

There are several manufacturers of small desktop Braille printers; their entire focus is on producing the highest quality Braille printers available in the market.

## II. LITERATURE REVIEW

Braille letters are small rectangular blocks called cells that contain many small palpable (capable of being perceived by senses or the mind) bumps called raised dots. The number and arrangement of these dots differentiate one character from another. Since the several braille letters generated as transcription codes of printed writing systems, the correspondence (sets of character designations) vary from language to language. Braille cells are not the only thing to appear in braille text, There may be many other things like symbols, arrows and bullets that are larger than braille dots, etc. A Braille cell includes six raised dots arranged in two lateral rows each having three dots [3,4].

## III. PROPOSED METHODOLOGY

Braille technology allows visually impaired or blind people to do common jobs such as writing, typing in Braille and printing in a text, browsing the Internet, downloading files, engaging in chat, music and reading documents. Braille utilizes cells of six raised dots, in two columns of three dots. The dot places on the left are numbered one to three, the ones on the right four to six. Each arbitrary sign is coded with certain dots present, and others absent. The aim is to print braille letters on paper one by one [4]. Bluetooth Module is used to send the alphabets to the microcontroller. The microcontroller will process these letters such as A, B, C, etc. to braille format. The microcontroller will control the servo motors and stepper motor. The braille letter will be printed by a servo motor shaft [4,5].

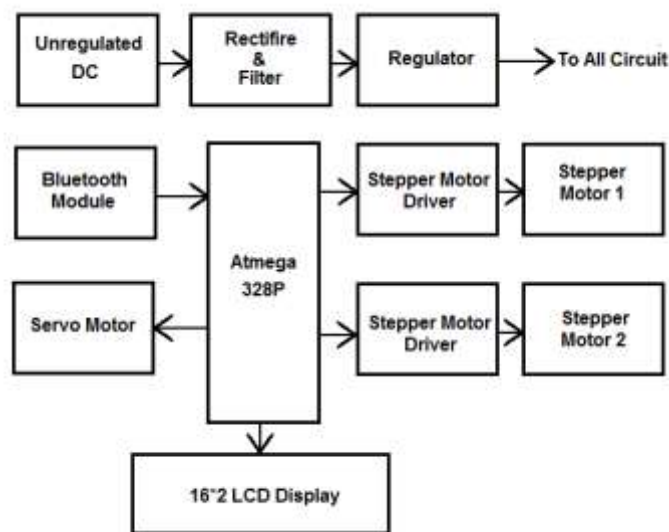

Fig.2 Block Diagram of Dot matrix Braille Printer

The servo motors will punch holes on the paper and will create braille letters on the paper. The servo motors will act one by one to print the braille letter. The first column of braille letter will be first printed. Then the stepper motor will move the paper forward. Then the second column of the braille letter will be printed. The stepper motor is used to move the paper forward to print the next letter [6].

The Braille printer can be operated as typewriter, i.e., the printer prints text as it is being typed on the computer; As the printer is being utilized as a typewriter, the input text can be given to the Braille printer from External keyboard and this input text is converted to Braille language with the help of Arduino IDE program [7].

External keyboard interface Atmega 328 which commands the two stepper motor and one servo motor to print the braille character on braille embosser paper.

### 3.1 Connectivity of Braille Printer

There are several ways in which Braille printers can be connected to a computer: serial/parallel ports, USB and Bluetooth. While the days of serial/parallel ports are gone, there are still adapters available that ensure that this method is still an option, although not as reliable. Braille currently offers a USB connection, as well as Bluetooth. USB is a direct connection between the Braille printer and local devices like computer, which is a very reliable and practical way of embossing.

### 3.2 Translation software for Braille printers

Text to braille documents is done by Braille translation software for any braille Printer.

### 3.3 Braille Paper

Unlike traditional printing paper, For Braille printer, Braille paper is a thick paper used specifically with Braille printers to print reading material for the blind and visually impaired. Braille paper grasp the shape of the Braille dot better than classical paper and lasts longer – ultimately making the reading process easier and more enjoyable for a blind individual.

### 3.4 An enjoyable user interface

The control panel is a user interface which allows the user to connect with the braille printer and provides complete printer control.

## IV. RESULT

The Braille Printer is very convenient and it easily prints the given input characters and it is very satisfying. Efforts are taken to make it as reliable as possible to give the blind people a very optimum result.



**Fig.3 Braille Printer.**

The above figure shows Braille Printer which is Bluetooth control as well as Voice Controlled. It is user friendly to blind users. The two stepper motor are used for the movement of the servomotor in the horizontal and vertical direction to print the Braille language on the Braille paper. The movement of motors is controlled by Atmega 328.

## V. CONCLUSION

This braille printer incorporates a very simple and cost-effective technology, which has the potential of decreasing the communication gap between visually disabled people and common people. It has made a strong backbone of communication for blind people and increased the literacy rate of the Blind population. It has given them a sense of pride, respect and enhanced their lives with dignity.

## REFERENCES

- [1]B.Dange,"DRISHTI- A cost effective braille printer" IJESCSE, ISSN: 2277-9477, ICRTFT' 2013.
- [2] PADMAVATI S., Economic Printing of Braille Document", IASIR, IJETCAS 14-346, 2014.
- [3]Paul Blenkhorn,"A System for converting braille into print", IEEE Transactions for Rehabilitation Engineering, vol.3, No.2,June 1995.
- [4]Choi H Lee W(2004), Tactile Display for the visually Disabled, in proceedings of IEEE/RSJ International Conference On Intelligent Robotics & System, pp 1985-1990.
- [5]Ryles, Ruby. "The impact of braille reading skills on employment, income, education, & reading habits." Journal of Visual Impairment and Blindness 90 (1996): 219-226.
- [6]Stangl, Kim, Yeh "3D printed tactile picture books for children with visual impairments: a design probe".
- [7]Patent WO 2011106762 A1- Low-cost, portable, mechatronics-based-braille embossing apparatus & writing system for the blind.
- [8]M. Nadeem, N Aziz et al., "A Comparative Analysis of Braille Generation Technologies", IEEE International Conference on Advanced Robotics & Mechatronics,2016.