

# PLC Based Automatic Liquid Mixing and Filling System

Sanohi Jatav<sup>1</sup>, Yoshin Engineer<sup>2</sup>, Roshan Duble<sup>3</sup>, Sai Adgale<sup>4</sup>

Department of Electronics and telecommunication, Viva Institute of Technology, Virar-401305

**Abstract**—In today's world of technology humans have been replaced by machines. These machines reduce human work and work even more efficiently which decreases probability of human errors. In traditional systems various kinds of devices were interfaced with help of wired technology which makes system look complex and rigid. In present scenario, most of the control systems are controlled with help of software units which eliminates human made errors and also increases efficiency of work and saves a lot of time of user. To eliminate large amount of mechanical faults and difficulties in tracing errors, programmable logic controller (PLC) based automation systems were introduced which overcomes these difficulties. The aim of this paper is to describe about the process of mixing and filling of bottles. Mixing of predetermined amount of liquids by user is done with help of PLC. After mixing is done, user defined volume of liquid is selected so that it can be filled in bottles in equal amount. Ladder logic diagram is used to program PLC which makes the whole system flexible and also user friendly as well as we can also control whole system of mixing and filling.

**Keywords**—automation, control systems, PLC.

## I. INTRODUCTION

An automated manufacturing process in the industry today means a final product with higher quality and more competitive due to factors such as standardization of process and product, speed of production, production schedule and continuous, reduction of waste and less chances to commit mistakes. Automation provides the tools we need to increase productivity and to do more, more effectively. The purpose of automation is to increase production and reducing the associated cost. The focus of automation in today's world of technology has shifted to increase quality, reliability and flexibility in any industrial manufacturing process. By adding computerized data, we can collect key information related to production, precisely improving data and reduce our data collection costs. This provides us with the facts to make the right decisions when it comes to reducing waste and enhancing processes.

PLC is the most important part of the system which makes the whole process automated, flexible and efficient. A liquid mixing and filling system with PLC allows the user to mix the liquid in different proportion and fill the bottle to a desired level without wasting liquid. To perform the sequential operation, ladder logic is used for programming. The system is controlled by a Selec MM1015 PLC which operates on 24V DC. It has 10 number of digital input ports and 6 number of digital relay output ports.

## II. METHODOLOGY

There are three holders, first compartment contains first sort of fluid, second compartment contains second sort of fluid with the individual solenoid valve associated on it, and center holder is blending and filling compartment. Blending holder is associated with a dimension sensor to detect the water level in it. Mixing compartment comprises of a DC adapted engine which will be utilized for blending the two various types of fluids.

## III. CONCEPTUAL MODEL

The whole system is divided in two major parts which are hardware and software.

### 3.1 Hardware illustration

The model number of PLC is MM1015. The PLC controls the input units and output units according to the program fed into it. Input supply to the PLC is given through a SMPS (Switched Mode Power Supply). The rating of the SMPS is 24V DC, 5Amp. The rating of the DC geared motor is 24V. Level switches (float type) are used to detect the level of liquids in respective containers. Solenoid valve connected to respective containers are used to control the flow of certain volume of liquid in both containers according to user's wish by setting fixed time interval in which both valves will open. After selecting the desired

amount of both liquids by user, these liquids are mixed in the mixing container with the help of DC geared motor. Relay board is designed for 24V.

### 3.2 Software illustration

There are different languages which are used for PLC programming. The lists of the methods are as follows:

- Ladder Diagrams
- Functional Block Diagram
- Statement List
- Logic Functions

Out of these languages, ladder diagram is the most widely used and is simple as compared to other languages. Ladder logic is the most important programming method used in PLC. Ladder logic is based on relay logic.

### 3.3 Working of PLC

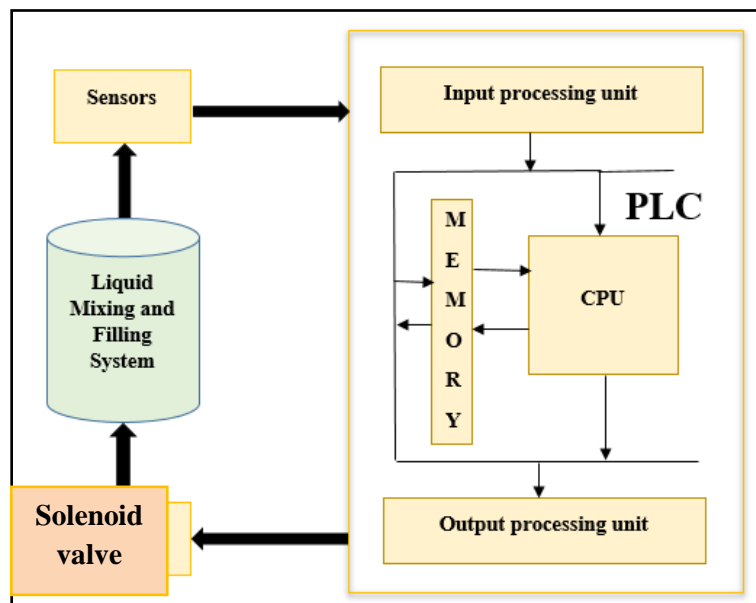

FIG.1 Working of PLC

Programmable Logic Controllers are used for continuously supervising the input values and generates the outputs based on the program. Every PLC system consists of components which are given as follows:

- i. CPU
- ii. A CPU unit comprises of memory and focal processor. The processor is in charge of executing all the vital calculations and handling of information by accepting the sources of info and delivering the suitable yields. Power supply

It supplies the required power to the whole system by converting the available AC power to DC power required for the CPU and I/O modules. The 5V DC output drives the computer circuitry.

- iii. Input/output module

The input and output modules of the PLC are used to connect the sensors and actuators to the system to sense the different parameters such as temperature, pressure and flow, etc. These I/O modules are of two types: analog or digital.

#### IV. BLOCK DIAGRAM OF LIQUID MIXING AND FILLING

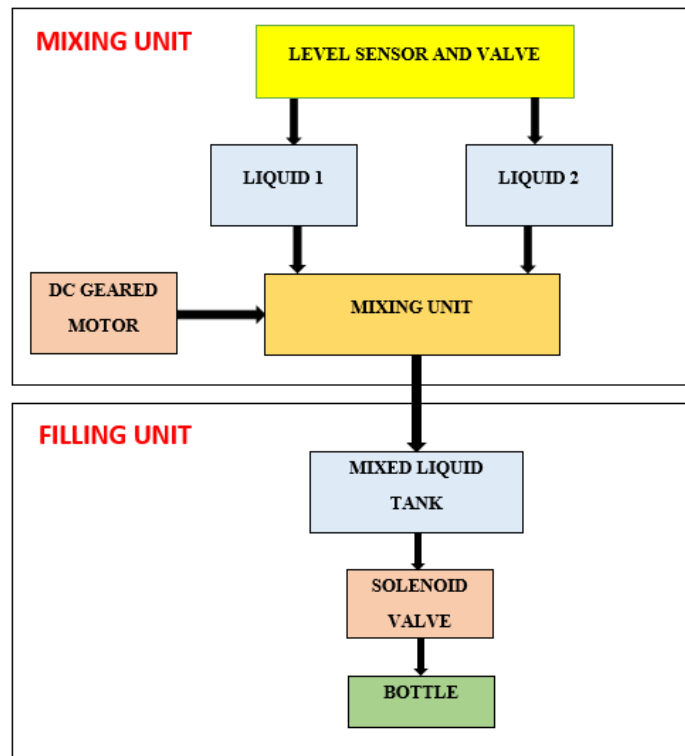

**FIG.2 Block diagram of model**

The various processes in this system is controlled by PLC. PLC is heart of the system. The system is controlled according to the PLC with help of programming. Fig.2 shows the block diagram of the whole process. Depending upon the user's need, proportion and amount of two different liquid to be mixed and filled, the closing and opening operation of solenoid valves connected to respective containers is controlled through PLC. PLC is a programmable device which scans all inputs connected to PLC input side module and process on its according to store program in its memory and generate outputs which are also interfaced on its output facet module i.e. motors, signals etc. It is also developed to replace mechanical relays, timers and counters. PLC consists of a power supply unit, input/output (I/O) unit, CPU, programming device and memory. PLCs work at 220VAC or 24VDC. The I/O unit acts as the interface between PLC and real time operating systems. CPU keeps a track of the PLC controller to avoid errors. They perform functions like logic operations, computer interface and arithmetic operations etc. Programming device is used to feed the program into the memory of the processor. The program is first fed to the programming device and later it's transmitted to the PLC's memory. Fixed amount of data is used by the CPU. System (ROM) stores the data permanently for the operating system. RAM stores the information of the status of input and output devices, and the values of timers, counters and other devices.

#### 4.1 The main components used are given as follows:

##### 4.1.1 DC geared Motor

Gear motors are essentially used to reduce speed in a series of gears, which creates more torque. This is achieved by a combined series of gears which are attached to the main motor rotor and shaft via a second reduction shaft. The second shaft is then connected to the series of gears or gearbox to create a series of reduction gears.

#### 4.1.2 Solenoid valve

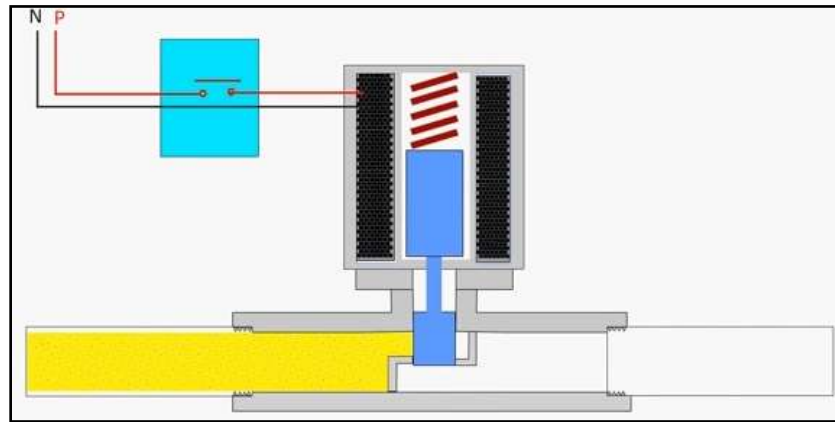

FIG.3 working of solenoid valve

A solenoid valve is an electromechanically controlled valve that takes out the need of a human for manual activity of valve. Solenoid valves are utilized at whatever point stream of media must be controlled automatically. A solenoid valve is a control unit that is electrically de-energized or energized to take into account the release or shut-off of stream. It is comprised of two sections which are solenoid and an electric loop with a mobile ferromagnetic center in its inside, and an iron plunger that is permitted to travel through the focal point of the curl. At the point when the loop is invigorated, the subsequent attractive field pulls the plunger to the center of the curl. A spring is likewise required to restore the plunger to its unique position

#### 4.2 Flow Chart

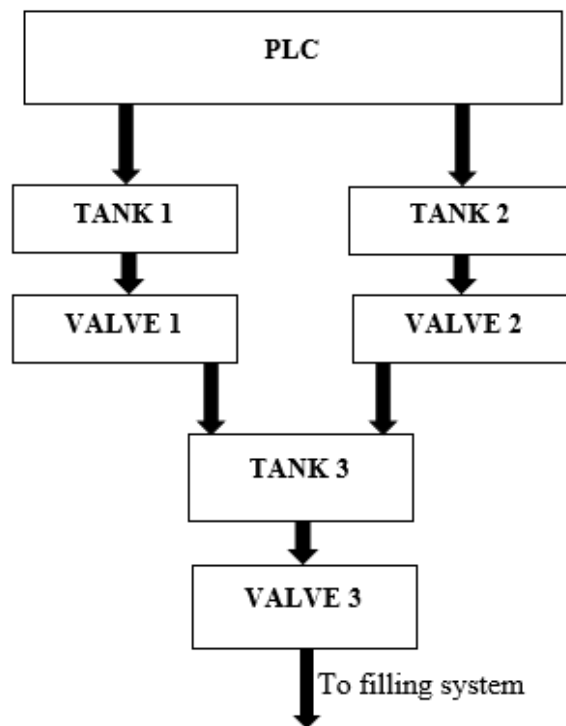
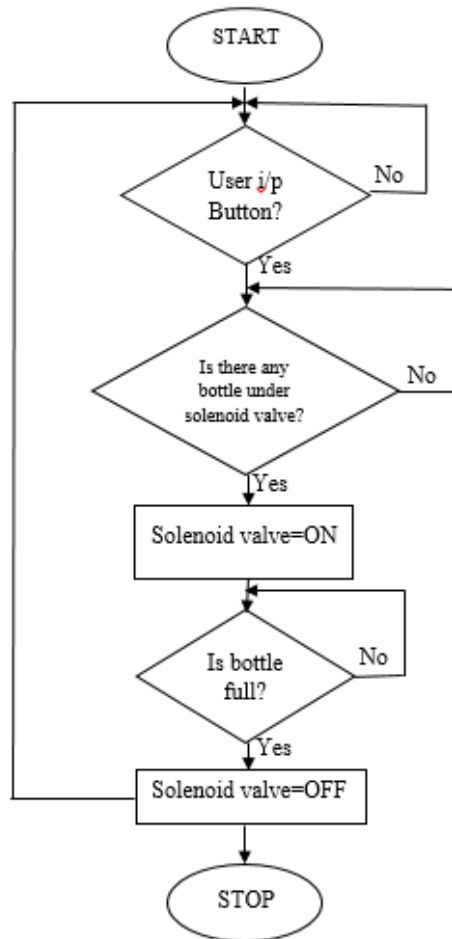

FIG.4 mixing system

**FIG.5 filling system**

## V. ADVANTAGES

The proposed system is very efficient due to its high reliability and resulting in low cost maintenance. It increases production as it reduces human errors. Capable of handling of very complicated logic operations. Efficient control techniques are obtained because various changes can be added further. Complete programming and reprogramming can be done as per the user's requirement. Programming is much easier to built as compared to embedded, C etc. because PLC ladder diagramming is easy to understand to other users. The system is not affected by external factors like industrial temperature, external noise etc.

## VI. APPLICATIONS

A set of actions in chemical, cement, food and paper industries is subsequent in nature which require time and take event-based decisions. PLCs are being used as total solutions to these batch problems occurring in these industries. In a batch process savings are developed from reduced cycle time and scheduling. This automation provides rigid control application to eliminate human made errors and to attenuate manual involvement. PLC's circuits are used to control the traffic lights and hence traffic flow is coordinated and managed to allow for more timely and direct rescue services. Automatic Door system is built and handled by PLC because it controls with better built-in sensor on both sides of the door to prevent a person getting hit by an automatic door swinging open. In big process plants, PLCs are being used oftenly. A PLC ensures that an equipment cannot be started unless all the conditions for safe start have been established. It also continuously monitors the conditions necessary for safe running of the

equipment and trip the equipment whenever any abnormality in the system is detected. The PLC can be programmed accordingly to function as an energy management system for maximum efficiency and safety.

## VII. RESULT

As Selec MM1015 PLC is used, different keywords are used to represent the quantity of liquid required by the user. Various combinations of liquid as per the requirement of user can be made and used. Solenoid valve are used as timer logic that remains open for a particular time slot by which mixing and filling of liquid in bottle as per the requirement of user.

## VIII. CONCLUSION

The purpose is to develop a PLC based automatic liquid mixing and filling system. We also obtained more information and knowledge about various automated processes used in industries. The PLC is used to control the whole system in any automation. Programmable logic controllers are flexible and easily adaptable to any typical industrial equipment's and are easily programmable. This system illustrates the mixing process of two liquids in various proportions and filling this mixture in bottle. This system avoids unnecessary wastage of liquid.

## REFERENCES

- [1] Rashmi Jakati1 , Anand Unnibhavi2,"AUTOMATION OF LIQUID FILLING AND MIXING/AGITATING SEQUENTIALLY WITH PRE-DEFINED VOLUME USING PLC",IJRET: International Journal of Research in Engineering and Technology eISSN: 2319-1163 | pISSN: 2321-7308
- [2] AZMAN BIN ABDUL RAHMAN, "LIQUID MIXTURE CONTROL SYSTEM USING PLC"
- [3] Harishchandra Mahale1, Nikhil Pagar2, Swapnil Devgir3,Vaibhav Thete4,Kavita Patil5,"A Review Based On Plc For Mixing And Filling Of Liquids", International Journal Of Engineering And Computer Science ISSN:2319-7242Volume -5 Issue -04 April, 2016Page No.16089-16092
- [4] Dheerendra Yadav &Keerti Sharma,"Control of an Industrial Mixer using PLC",International Journal of Engineering Research and Applications (IJERA) ISSN: 2248-9622
- [5] "Application of PLC for Arranging Bottle in Beer Filling Production Line" ZHANG Tianxia, DONG Feng , YUAN Hao Tianjin Key Laboratory of Process Measurement and Control, School of Electrical Engineering and AutomationTianjin University, Tianjin 300072, China.
- [6] D. Baladhandabany, S. Gowtham, T. Kowsikkumar, P. Gomathi, 'PLC Based Automatic Liquid Filling System', International Journal of Computer Science and Mobile Computing, Vol. 4, Issue 3, March 2015, pg.684-692
- [7] T.Kalaiselvi , R.Praveena, "PLC Based Automatic Bottle Filling and Capping System With User Defined Volume Selection", International Journal of Emerging Technology and Advanced Engineering", (ISSN: 2250-2459 )2012.
- [8] Ashish Tiwary, Nitesh Kumar, Ankita Anil, Y Saurabh Ranjan,"PLC Based Bottling System in Industrial Automation",Imperial Journal of Interdisciplinary Research (IJIR) Vol-3, Issue-4, 2017 ISSN: 2454-1362
- [9] Jaymin Patel,"PLC(Programmable Logic Controller) BASED AUTOMATIC BOTTLE FILLING",International Journal of Engineering Research and General Science Volume 3, Issue 3, May-June, 2015 ISSN 2091-2730
- [10] Ameer L. Saleh1, Lawahed F. Naem 2, Mohammed J. Mohammed3,"PLC Based Automatic Liquid Filling System For Different Sized Bottles",International Research Journal of Engineering and Technology (IRJET) e-ISSN: 2395-0056 Volume: 04 Issue: 12 | Dec-2017 www.irjet.net p-ISSN: 2395-0072.