

## Development of charging station for electric vehicle

Hardik makwana<sup>1</sup>, Tanmay kadam<sup>2</sup>, Sumit jaiswar<sup>3</sup>, Ajay gupta<sup>4</sup>

Department of Electrical Engineering, Mumbai University, INDIA

**Abstract-** Our project represents the Charging station (CS) infrastructure for feeding the EVs. An EV charging station is also known as EVSE which is an element in infrastructure that supplies electric energy for the recharging of electric vehicles. India is one of the largest markets for automobiles with electric vehicles. Electric vehicles (EVs) are becoming increasingly popular in the India. Buyers are attracted towards EV which have benefits including energy efficiency and is also environment friendly. The charging event data includes the start date, start time, length of parking time, length of charging time, amount of energy delivered, and the postal code entered by the user during charge point account registration. Analytical methods were proposed to obtain information about EV charging behavior, charging station occupancy, and geo-location of charging station users. The idea presented here was time and cost saving. It was also scalable to other organizations that own charging stations. The data presented here can be used as a reference for EV charging station usage in other towns in the India that do not have EV charging stations, but are planning to develop such.

**Keywords-** Electric Vehicle Charging Station, Plug in Electric Vehicles (PEVs), Solar Energy, Grid, Connector.

### I. INTRODUCTION

In battery technology various Improvements were made by car manufacturers in plug in electric vehicles for the design. There has been significant increase in usage of electric vehicles which leads to add on power loads. Due to increase in loads, the electrical parameters like harmonics and decrease in power factor has significance downfall in the utility company. The Latest advance technology has given suggestion to incorporate Photo voltaic charging stations for electric vehicles which are plug in with local electricity supply, thereby power usage is minimized especially in peak load. Globally places like Mexico, Arizona, Mississippi and Maine have incorporated charging stations with Solar Source, in- case of developing nations, it's a new concept. With this introduction of new technology, life quality has substantially has increased in developing countries, there by domains like education and in turn economic developments is in progress state. Also in off-grid mode, these electric vehicle can also be charged and used, which leads to fuel consumption reduction and fuel transportations cost is minimized overall. At home or work, some of the electric vehicles have onboard converters that can plug directly into a standard electrical outlet or a high-capacity appliance outlet. Others require charging station that provides electrical conversion, monitoring, or safety functionality. Our station can be carried during travelling. Public charging stations are nothing but facilities which are provided by electric utility companies or are located at retail shopping centers and operated by many private companies. Charging of batteries of electric vehicles through charging station does not require any license under the provision of the Electricity Act 2003.

## II. THE SYSTEM ARCHITECTURE OF EV CHARGER

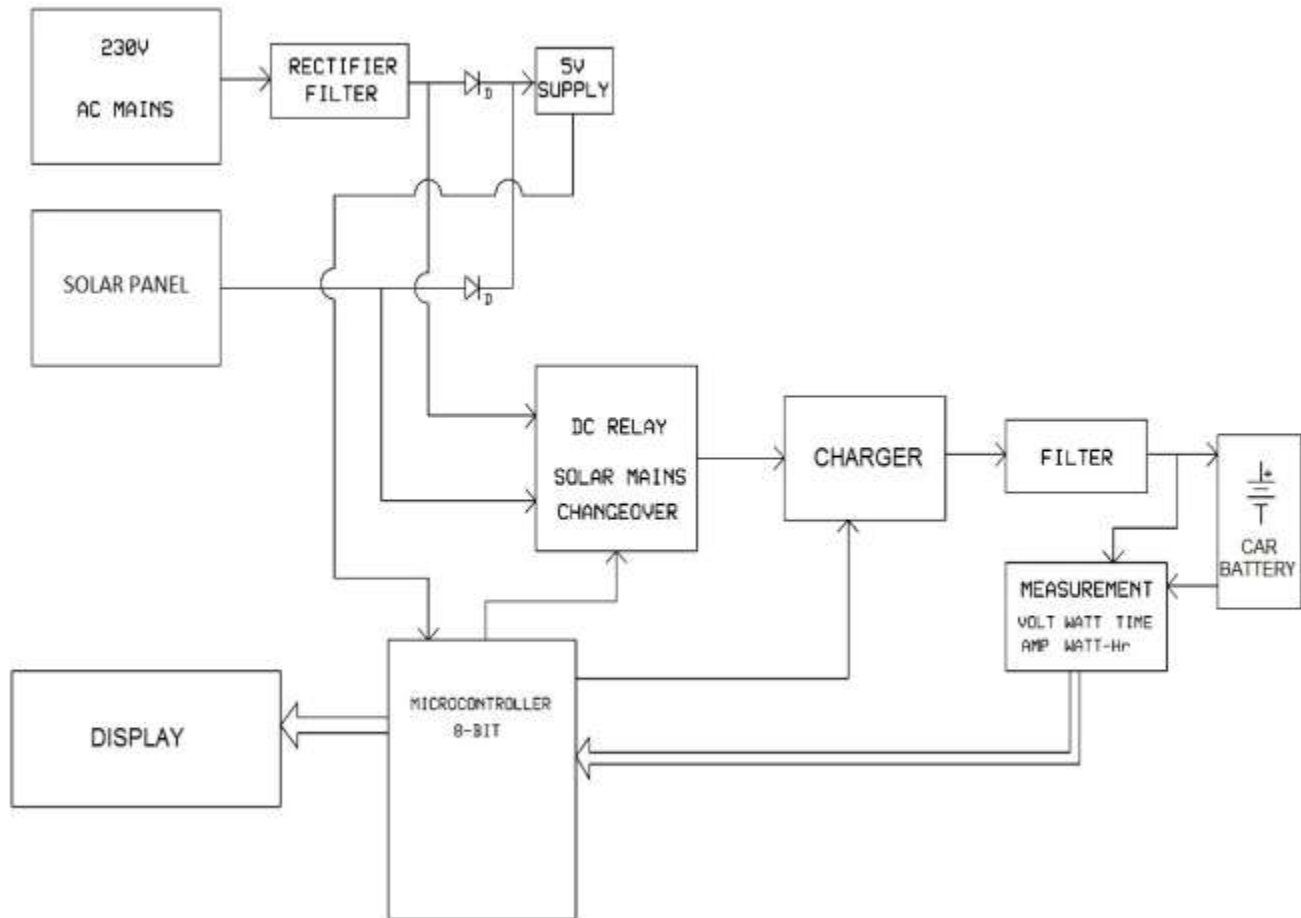

Fig 1: Block Diagram of EV Charger

## III. WORKING

According to the circuit diagram there are two sources 230 volt A.C mains and solar, which are used to charge battery of electric vehicle. Solar is used as primary source of energy and 230 volt A.C is considered as secondary source of energy. Solar panel provides power during day time and 230 volt mains during the night period.

Center tapped transformer is used to provide variable voltage (say 60volt).rectifier is used to convert 60volt A.C to D.C voltage.1k LED is used as a indicator after the  $\pi$  filter where the D.C output from rectifier is smoothened. Diode, an electrical component that allows the flow of current in only one direction which is represented by a triangle with a line across one vertex. LM7805 is a regulator which regulates the voltage and has output of 5volt which is provided to the Arduino as it requires 5 volt for its operation.

The voltage is compared at the relay where the solar and mains are compared by the program feed in the Arduino. By that program the primary supply is given first preference than the main supply and consequently the charging begins from it. The 16x2 LCD display is used to display parameters such as vehicle initial charging, charging time required, voltage, current, power consumption and rate per unit.

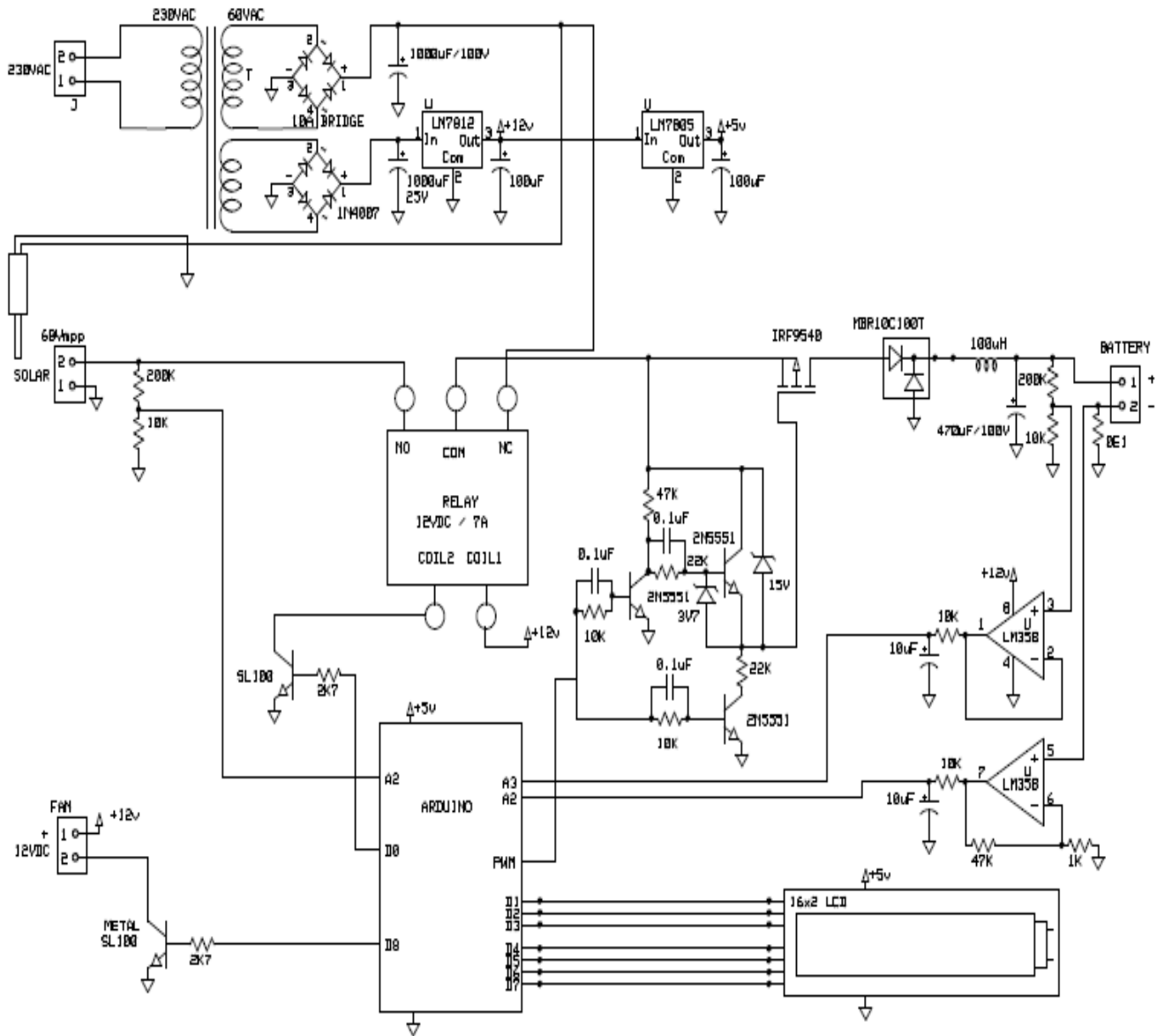

Fig 2: circuit diagram of charging station

IV. MATHEMATIC MODULATION FOR CHARGING FACILITY

4.1 Input given to battery

Consider voltage  $V_2 = 5V$  is available at pin A2 of Arduino and corresponding circuit diagram is shown in fig.2.

$$V_1 = I_B \times 0.01 \tag{1}$$

$$V_2 = V_1 (1 + 47/1) = V_1 (48)$$

$$V_2 = I_B \times 0.01 \times 48$$

$$V_2 = 0.48 I_B \tag{2}$$

As we know that Arduino operates at 5V

$$5 = 0.48 I_B$$

$$I_B = 10.4167$$

The range 0-1023 comes from the A/D Converter built in Arduino. It takes voltage reading and compare it to analog reference voltage (i.e.5 volt, it can be changed). It converts that reading to binary number. The maximum number we can represent with 10 binary bit is 1023. Therefore, a reading of 0V is converted to number 0; a reading of 5V is converted to number 1024 and so on.

I/p Voltage,

$$XV = (5/1024) \times \text{Hex bit} \quad \dots\dots\dots (3)$$

I/p Current,

$$XA = (10.4167/1024) \times \text{Hex bit} \quad \dots\dots\dots (4)$$

#### 4.2 Battery %

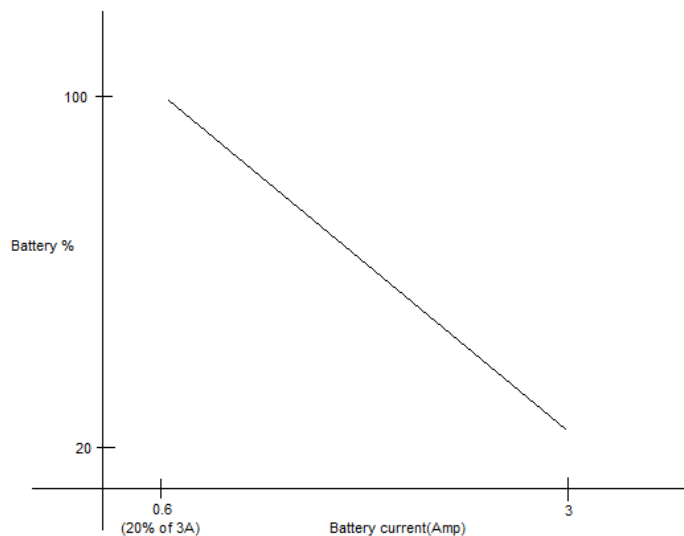

**Fig 3: Graph of Battery % and Battery current**

Equation of straight line on graph,

$$y = mx + c$$

Let, y be the battery % and x is Battery current, slop m is given by,

$$m = (y_2 - y_1) / (x_2 - x_1) = (100 - 20) / (0.6 - 3) = 80 / -2.4$$

$$m = -100/3$$

Let, x = 0.6

$$y = mx + c$$

$$100 = (-100/3) \times 0.6 + c$$

$$c = 100 + 20$$

c = 120

$$\text{Battery \%} = [(-100/3) \times \text{battery current}] + 120 \quad \dots\dots\dots (5)$$

**4.3 Charging Time (t)**

Charging Time (t) = Battery Capacity (Amp-hr) / Charging current (Amp)

$$= 100 \text{ Amp-hr} / 3 \text{ Amp}$$

$$= 3.33 \text{ hr}$$

If Battery is fully discharged then charging time is equal to 3hr = 60min X 3 = 180min will be required to charge full battery.

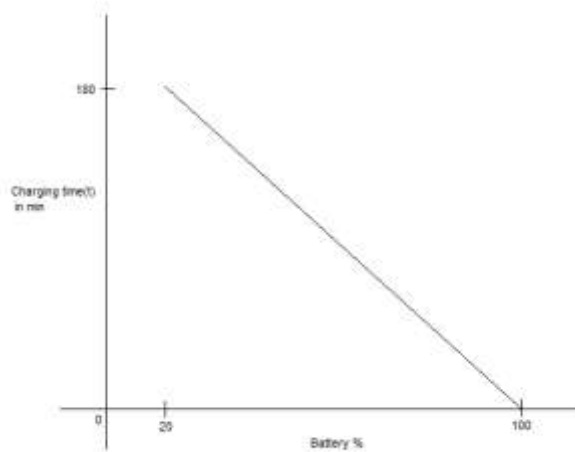

**Fig 4: Graph Of Charging Time (t) And Battery %**

Equation of straight line on graph,

$$y = mx + c$$

Let, y be the Charging time and x is Battery %, slop m is given by,

$$m = (y_2 - y_1) / (x_2 - x_1) = (180 - 0) / (20 - 100) = -9/4$$

Let, x = 20 %

$$y = mx + c$$

$$180 = (-9/4) \times 20 + c$$

$$c = 180 + 45$$

$$c = 225$$

$$\text{Charging Time (t)} = [(-9/4) \times \text{battery \%}] + 225 \quad \dots\dots\dots (6)$$

**V. THE DEVELOPMENT DIRECTION OF ELECTRIC VEHICLE CHARGING STATION**

There is tremendous potential but considerable constraints as well in EVSE. Electric vehicle manufacturing is rising in India with many automobile companies (e.g. Tata, Mahindra, Suzuki, TVS, Hero etc.) allocating considerable capex and R&D for them. Unit economics for producers as well as pricing for consumers are looking favorable and with further reduction in battery costs, it is very probable in a short period of time that the total cost of ownership (TCO) will start looking favorable for the mass-market

user. However, private companies are currently restricted from building the charging ecosystem because the Electricity Act 2003 doesn't allow non-power distributors to resell electricity / set charging stations. That needs to be fixed to enhance capacity. There are currently 350 charging points in the country as compared to 215,000 in China and the government can't be expected to create the entire eco-system on its own - a supportive framework to enable private enterprise should be deployed instead.

## **VI. CONCLUSION**

EV is a fundamental element in recognized plans to increase the Indian energy independence and also improve the environment. The EV owners do not enjoy the benefits of the standardized refueling facilities familiar to the owners of conventionally-powered vehicles, and there is limited consensus on how to standardize and expand the EVSE infrastructure. The Existing EV and recharging facilities are safe and effective to get to the next level of EVSE availability.

## **REFERENCES**

- [1] PEV registrations - National Renewable Energy Laboratory analysis, R.L. Polk, POLK\_VIO\_DETAIL\_2014, May 2015.
- [2] (Péter Kadar and Andrea Varga, January 31 - February 2, 2013)
- [3] Off-Grid, Low-Cost, Electrical Sun- Car System for Developing Countries (Otward M. Mueller<sup>1</sup> and Eduard K. Mueller, ©2014 IEEE)
- [4] System Architecture of a Modular Direct-DC
- [5] PV Charging Station for Plug-in Electric Vehicles
- [6] (Christopher Hamilton, Gustavo Gamboa, John Elmes, Ross Kerley, Andres Arias, Michael Pepper, John Shen, and Issa Batarseh, 2010 IEEE)
- [7] <https://www.mahindrae2oplus.com>
- [8] <http://www.anantcars.com> (Banneragatta Road, Bengaluru)
- [9] Charging station Challenges (Chris Miyachi, chair, IEEE Cloud Computing,)