

## Design and implementation of PWM Inverter

Mr. Prince Singh<sup>1</sup>, Mr. Shailendra Yadav<sup>2</sup>, Mr. Gopi Gupta<sup>3</sup>

<sup>1</sup>Department of Electrical Engineering, Viva Institute of Technology, Virar, Mumbai University  
Email: princesingh95030@gmail.com

<sup>2</sup>Department of Electrical Engineering, Viva Institute of Technology, Virar, Mumbai University  
Email: guptagopi997@gmail.com

<sup>3</sup>Department of Electrical Engineering, Viva Institute of Technology, Virar, Mumbai University  
Email: engshailendra12@gmail.com

**Abstract**—this project aims to design and implement a single-phase inverter that converts DC voltage to AC voltage at high efficiency and low cost. The DC voltage is stepped up by employing a boost converter to a much higher voltage. This high voltage DC source is then transformed into an AC signal using PWM (pulse width modulation). To deliver such performance, the power inverter is driven by high-performance PIC 16F877A microcontroller units (MCUs) that can achieve high-level inverter control, and therefore microcontroller is the heart of the system and controls the complete system. The microcontroller is programmed using an embedded compiling program and in specific mikroC pro to come up with sinusoidal pulse width modulated (SPWM) pulses which are applied to drive H-bridge. By alternate switching switches of two legs of H-bridge alternating DC voltage is converted into AC voltage.

**Keywords**—Single Phase Inverter, Boost Converter, Microcontroller, LC Filter, Gate driver, Simulation.

### I. INTRODUCTION

Electronic devices run on AC power, however, batteries and few sources of power generation produce a DC voltage so it is necessary to convert the voltage into a source that devices can use. Hence a requirement for power rating inverter to smoothly operate electrical and electronic appliances. Most of the commercially available inverters are square wave or quasi square wave inverters.

### II. LITERATURE REVIEW

The Literature review contains a quick discussion of some recent works in PWM inverters because of the recent growth of Digital signal processing and microcontrollers, real-time control of those converters have become easy and economical.

A microcontroller-based advanced technique of generating sine wave with minimized harmonics is implemented during this paper. The proposed technique aims to design and implement a voltage regulated inverter with ripple-free and glitch-free output sine wave which will operate electronic devices efficiently

[1] Yaosuo, et al. have reviewed the topologies of the single-phase inverter working in a distributed generation system, they have analyzed the single and multistage single phase inverter and given an overview of 4 switches and 6 switch inverter topologies

[2] M. A. AlNema et al. have proposed a replacement topology of inverter in which with single power stage the output voltage of upper magnitude than the input may be achieved

[3] Ian D. de Varies has devised a low loss capacitance driver circuit topology. Full bridge converters are very sensitive to input switching waveforms

[4] Wilson et al. have proposed a gate drive circuit which achieves quick activate and switch off transient times to scale back switching losses and conduction losses, additionally to the current it also helps in recovering any heat loss that happens because of MOSFET drive

[5] This paper gives the planning and implementation of a single-phase inverter that produces a symmetric AC output voltage of desired magnitude and frequency

[6]The authors have done a close analysis of the resultant signal. It is further proposed that the utilization of an LC filter at the output of such an inverter leads to nearly perfect sinusoidal output

[7]F.G Turnbull has introduced an effective technique that eliminates the third and fifth harmonic voltage present in a single leg center tap (half-bridge) single-phase inverter. He has stated that with the addition of two more switches or one leg (full bridge), the fundamental frequency component of the output ac voltage will be controlled from maximum to zero without reintroducing the third and fifth harmonics

[8]Joachim Holtz has done a comprehensive analysis of the various types of PWM techniques like as carrier-based PWM and non-carrier based PWM, various parameters namely harmonic spectrum, torque harmonics and dynamic performance for analyzing the performance for various PWM techniques have been discussed

[9]The proposed alternative approach is to exchange the conventional method with the utilization of microcontroller

[10]Mamun et al. in used an 8-bit microcontroller to get the SPWM gating pulses. In microcontrollers the sampling frequency is limited by interrupt latency, also the constraints imposed by the finite word length limits the microprocessor's computation capability Hence authors have sought the utilization of Digital Signal processor to implement the modulation needed for the inverters

[11]The overview and division of the possible soft-switching PWM converters for high power application is presented during this paper.

### III. SYSTEM ARCHITECTURE AND DESIGN

Pulse Width Modulation or PWM technology is employed in Inverters to give a steady output voltage of 230 or 110 V AC no matter the load. The Inverters based on the PWM technology are more superior to traditional inverters. The utilization of MOSFETs in the output stage and the PWM technology makes these inverters ideal for all types of loads. In addition to the pulse width modulation, the PWM Inverters have additional circuits for protection and voltage control. The system will comprise two parts the Hardware Part and also the Software Part.

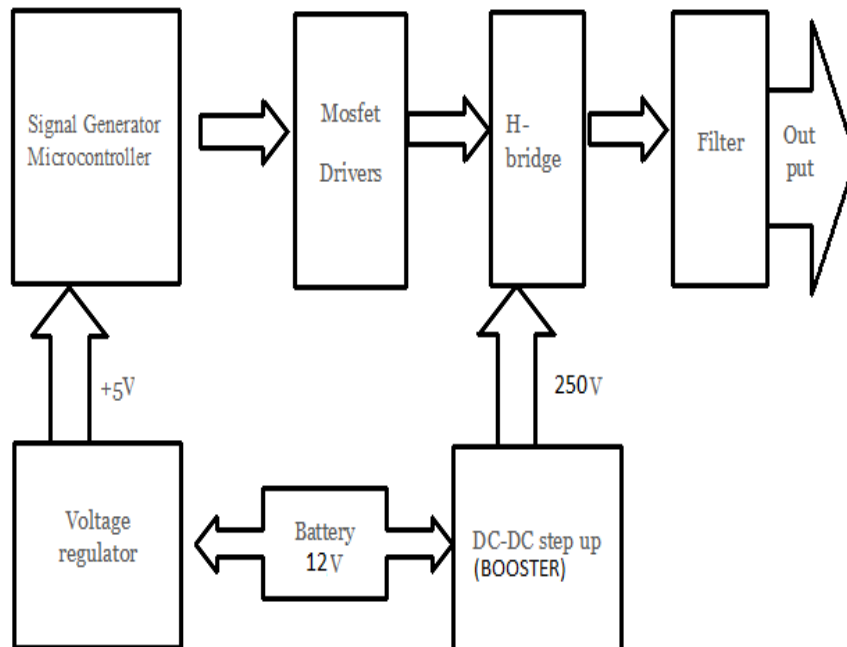

**FIGURE 1: Block Diagram**

The Architecture consists of following hardware components.

### 3.1 PIC16F877A

The microcontroller has 40 pins, 33 pins are set as 5 Input/Output ports: PORTA, PORTB, PORTC, PORTD, and PORTE. PORTA contains 6 pins, PORTB/PORTE/PORTD contains 8 pins while PORTE contains 3 pins.

### 3.2 Boost converter

A boost converter is a DC to DC converter where an output voltage greater than the source voltage. A boost converter is typically called a step-up converter since it "steps up" the source voltage. Since power must be conserved, the output current is below the source current.

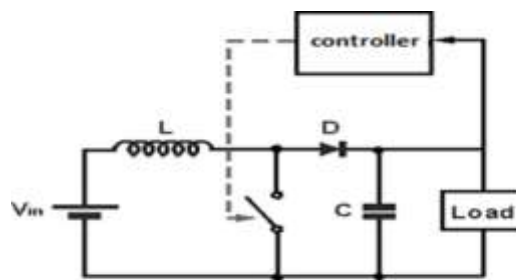

**FIGURE 2: Booster Circuit**

### 3.3 Gate Driver

For driving the gate of the MOSFET there are two fundamental categories, are low side driver and high side driver. The high side means the source of the MOSFET of the power element can float between the ground and high voltage power rail and the low side means the source of the MOSFET is always grounded [2]. For driving the high side MOSFET we used TLP250 and a capacitor of 50V, 100µfarad in the output of TLP250, this capacitor is termed a bootstrap capacitor. The capacitor in the output of TLP is employed for protection.

The pinout description is:

- 1: N.C,      2: Anode,
- 3: Cathode,   4: N.C,
- 5: GND,      6: V0 (output),

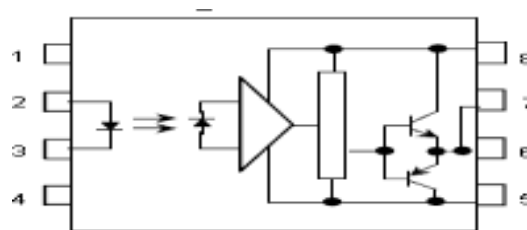

**FIGURE 3: Pin diagram of the High side driver circuit TLP250**

### 3.4 Battery as a source

The battery has 12 Volt, 10 Ah Sealed Lead Acid batteries have a valve regulated, spill-proof construction for trouble-free and safe operation in any position.

### 3.5 PWM&MOSFET

Pulse width modulation, or PWM, has become an accepted method for generating unique signals, because of the advancement of microcontrollers and its power efficiency. To form a sinusoidal signal, PWM uses high-frequency square waves with varying duty cycles. The duty cycle is the % of the time the signal is relative to the period. This suggests because of the duty cycle increases, more power is transmitted PWM requires rapid on and off signals, which can be achieved using high power MOSFETs. MOSFETs are ideal switches because of the low power loss when the device is activated.

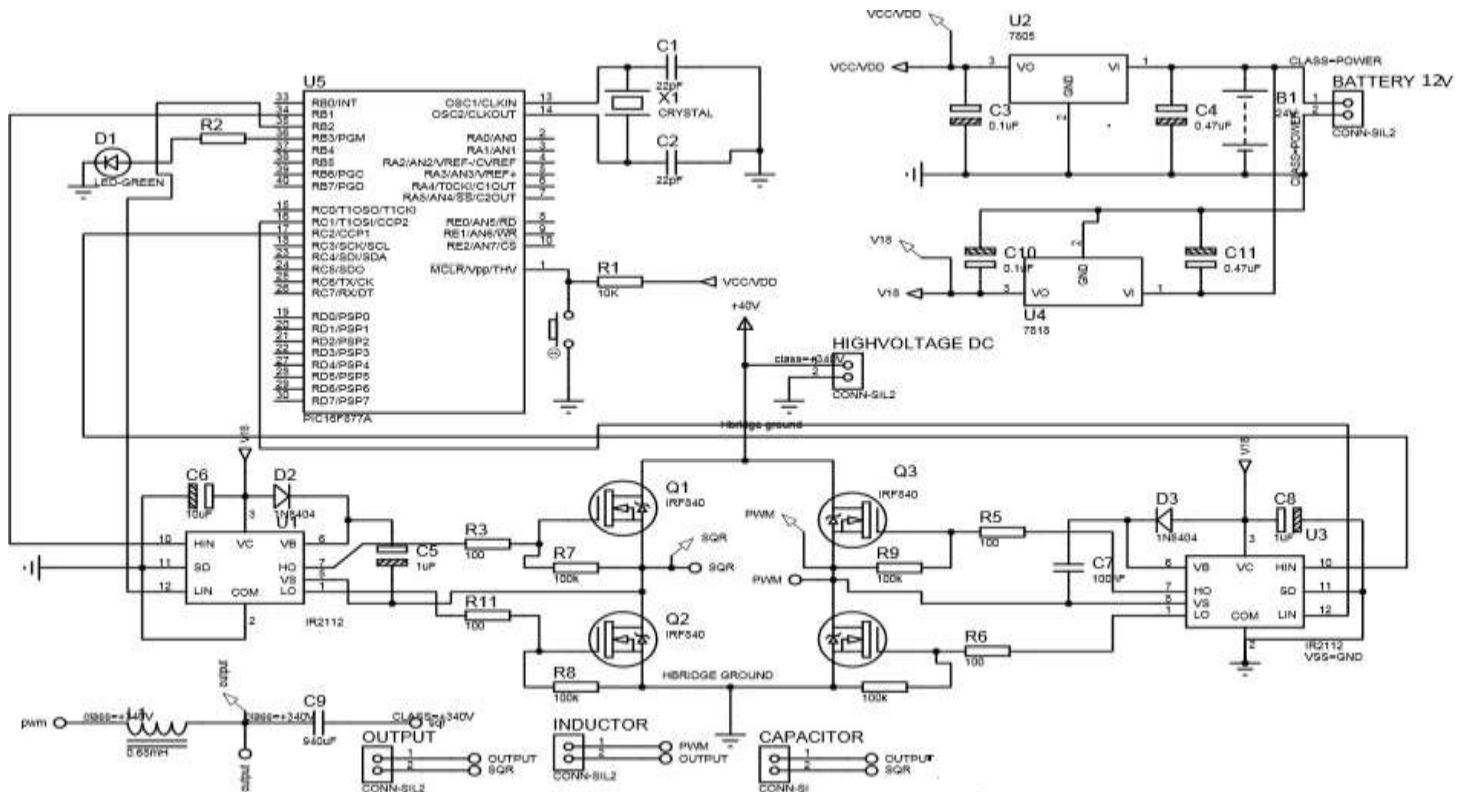

FIGURE3:Circuit Diagram

## IV. DESCRIPTION

Pin 13 and pin 14 of the microcontroller are connected to 20MHz quartz crystal. A stable 5 volts to power the microcontroller is supplied from the output of 7805 IC voltage regulator. The LED connected at pin 36 will light green to indicate if the inverter is on and switch off when it is not working. Pins 34 and 35 outputs 50Hz square wave 180 degrees out of phase to drive one side of the H-bridge and pin 16 and pin 17 output pulse width modulated signal of 5KHz to drive the opposite side of H-bridge. During simulation IR2112 IC s employed rather than IR2110 but their function is analogous and that they do operate the identical way. Pins 10 and 12 receive logic inputs from the microcontroller to drive high side and low side Mosfet respectively. The signal from pin 12 is passed to pin 1 even as it is without being stepped up and from pin 1 is connected to low side Mosfet gate through a gate resistor. That from pin 10 is employed to charge and discharge bootstrap capacitor which successively provides the much needed high voltage to drive high side Mosfet through gate resistor.

At the H-bridge rail voltage is provided comparable to  $V_{max}$  of the output RMS voltage needed. The output of the H-bridge is a 3 level pulse with modulated signal centered at 0 voltage and with a maximum voltage equal to rail voltage of H-bridge. This voltage is given to a low pass passive filter fabricated from inductor, capacitor, and resistor. The inductor must be able to pass maximum current rated for the Mosfet and capacitor be able to handle the maximum voltage which is up to the rail voltage. Across the output terminals of the filter is where we are now supposed to connect the load.

#### 4.1 ADVANTAGES

- [1] Energy efficient
- [2] Low power consumption
- [3] High power handling capacity
- [4] It will be used for domestic application
- [5] Compatible with today's digital microprocessor
- [6] It makes the system more reliable.
- [7] It will be used as a speed changer for AC drives.

#### 4.2 DISADVANTAGES

- [1] It is expensive.
- [2] High switching loss because of the high PWM frequency.
- [3]

#### 4.3 APPLICATIONS

This project has enormous applications. It can be utilized in the following areas:

- Uninterrupted power supply
- HVDC Transmission
- Ac energy conversion from renewable energy sources like a photovoltaic cell, fuel cell.
- Medical instruments.
- Electric vehicle

### V. CONCLUSION

Pulse width modulated (PWM) inverters are among the foremost used power electronic circuits in practical applications. These inverters are capable of producing ac voltages of variable magnitude likewise as variable frequency. The standard of the output voltage can even be greatly enhanced compared with those of square wave inverters. The PWM inverters are very commonly utilized in adjustable speed ac motor drive loads where one must feed the motor with variable voltage, variable frequency supply. For wide variation in drive speed, the frequency of the applied ac voltage must be varied over a wide range. The applied voltage also has to vary almost linearly with the frequency. PWM inverters are of a single-phase similar to three-phase types. The principle of operation of 3-phase type PWM inverter remains almost like that of 1-phase PWM inverter.

### REFERENCES

- [1] An Ali Qazalbash, Awais Amin, Abdul Manan, and Mahveen Khalid, "Design and Implementation of Microcontroller based PWM technique for Sinewave Inverter", International Conference on Power Engineering, Energy and Electrical Drives, POWERING '09. 2009 pp.163-167, IEEE.
- [2] Y. Xue, L. Chang, J. Bordonau and T. Shimizu, "Topologies of Single Phase inverters for small Distributed Power Generators: An overview," IEEE, Power Electronics, pp. Vol 19, No 5, 2004
- [3] M. A. Al-Nema and S. M. Al-Layla, "Analysis, Design, and implementation of modified single-phase inverter," in IEEE Proceedings, 2007.
- [4] I. D. Vries De, "A Resonant Power MOSFET Gate Driver," in IEEE Conference Paper, 2002
- [5] W. Eberle, Y. and P. C. Sen, "A Resonant Gate Drive Circuit with Reduced MOSFET Switching and Gate Losses," in IEEE, IECON 2006 - 32nd Annual Conference on, Paris, 2006.

- 
- [6]R. Senthil Kumar, "Design of Single-Phase inverter using dsPIC30F4013," International Journal of Engineering Science and Technology, pp. 6500-6506, 2010.
- [7]H. Kim and S. K. Sul, "Analysis on output LC filters for PWM inverters," in IPEMEC, IEEE.
- [8]F. G. Turnbull, "Selected Harmonic Reduction in Static D-C—A-C Inverters," IEEE PAPER, New York 1964.
- [9] J. Holtz, "Pulsewidth Modulation - A survey," transactions on Industrial Electronics, IEEE pp. 400-440, 1992.
- [10] S. M. Mohaiminul Islam, Gazi Mohammad Sharif "Microcontroller Based Sinusoidal PWM Inverter for Photovoltaic Application", First International Conference Developments in Renewable Energy Technology ( ICDRET), December 2009 pp. 1-4, IEEE.
- [11] A. A. Mamun, M. F. Elahi, M. Quamaruzzaman and M. U. Tomal, "Design and implementation of single-phase inverter," International Journal of Science and Research, Vol 1,2, Issue 2, 2013.
- [12] Michihira, Yonemori, and Nakaoka. Resonant-pole type ZS-PWM dc-dc converter using secondary control. National Conference of the IEEE Japan, 4-170(1995).