

Design and Fabrication of Automatic Dustless Chalk making Machine

Hardik Chavan¹, Pratik Ghodke², Satish Hatkar³, Nilesh Nagare⁴

¹Department of Mechanical Engineering, Mumbai University, Mumbai
Email: hardikchavan707@gmail.com

²Department of Mechanical Engineering, Mumbai University, Mumbai
Email: pratioghodke@gmail.com

³Department of Mechanical Engineering, Mumbai University, Mumbai
Email: satishhatkar888@gmail.com

⁴Department of Mechanical Engineering, Mumbai University, Mumbai
Email: Nileshnagare@viva-technology.org

Abstract—In today's world of automation the traditional chalk making machine is left behind due to lack of automation in this industry. Our project work includes the design and fabrication of automatic dustless chalk making machine. Our main aim is to automate the traditional chalk making machine for ease of manufacturing. The machine consists of traditional machine components such as Hopper, Mould and Ejectors as well as electronic system for the purpose of automation.

The basic working of this machine is to mix the ingredients of chalk in the Hopper with the help of AC motor, this mixture is poured in the mould and dried with the help of heating system. The ejection system ejects the chalks from the mould, the ejected chalks are collected in a tray. All the above processes are automated with the help of Electronic Control Unit (ECU). The automation system consists of speed controller of AC motor, sweeping movement is controlled by servo motor, the sliding movement of the mould and ejection movement is control by stepper motors. The sensors like temperature and humidity, displacement are used to sense various parameters.

Keywords—Automatic, Chalk machine, Dustless, Engineering, Mechatronics.

I. INTRODUCTION

In our project we are designing and fabricating the automatic dustless chalk making machine. Our main purpose of the project is to reduce the manpower and production time. In order to achieve this we have used electronic control unit such as Arduino-Mega for the automation in the traditional chalk making machine and implementing of direct heating of the mould in order to reduce the drying time thus making the process faster .

The ECU controls the various motor viz. stepper motor and servo motor, it also alters its parameters like speed and movements. We use induction heating to heat the water and this heated water is circulated through the mould surface for better heating. For easy ejection of the chalk from the mould the ejectors are used to penetrate through the mould holes pushing the chalks downward in the tray placed below.

The chalk composition used is same as the dustless chalk available in the market. The machine will produce 225 chalk at one pass, we can also produce different color chalks as per requirement.

II. PROBLEM DEFINITION

2.1 Problem statement

After searching for various prototypes of chalk making machines, we found out that the low scale machines are not automatic and loaded manually. The processes take several hours for completion of one batch of chalks. The available automatic machines required skilled labour, more area for installation and their initial cost is high as compared to low scale machines.

The low scale chalk making industry uses old school chalk making machines which are incapable of mass production. The machine used require more efforts and man hours which in leads to high labour cost and eventually reduces the profit. The chalk

produce from this type of machine takes more time for drying. Due to more idle time the quality of the chalk manufactured is poor.

2.2 Objective

The main objective of the project is to design and fabricate Automatic Dustless Chalk making machine to reduce the manpower, process time, increase the production and quality of chalk and better utilization of traditional chalk making machine.

2.3 Advancements

Following modifications will be made in our machines to overcome the drawbacks of old school machines-

1. In our machine we are using ECU control for automation of machine, which will control the various operation of the machine.
2. For the purpose of reducing the process time of drying we are implementing integrated heating of mould.
3. Our machine can produce 110 numbers of chalk per batch in approx. 2hrs, which eventually reduces production lead time and hence increase in productivity.
4. As the chalk business is quantity type more production of chawks, ultimately increases the profit of manufacturer.
5. As the machine is fully automated the quality of product will be as per desired standard.
6. The efficiency of this machine will be higher than traditional chalk machines.

As the processes are automatic stepper motor are used to move the mould from one section to another and actuation of ejector is also carried out by the stepper motor of high capacity. To control the stepper motors by Arduino Megarelay drivers are used for signaling the direction of rotation of stepper motor. Figure below shows a basic circuit of relay driver.

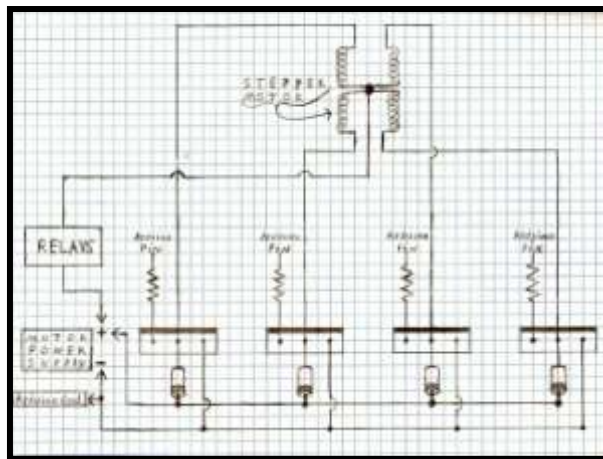

FIGURE 1: Relay circuit of one stepper motor

The Arduino uses DC power source to operate. To control the AC motor by Arduino an AC relay switch is used. HL-52S 2 channel relay is suitable to control AC motor of 240V. Figure below shows circuit diagram of AC motor control relay.

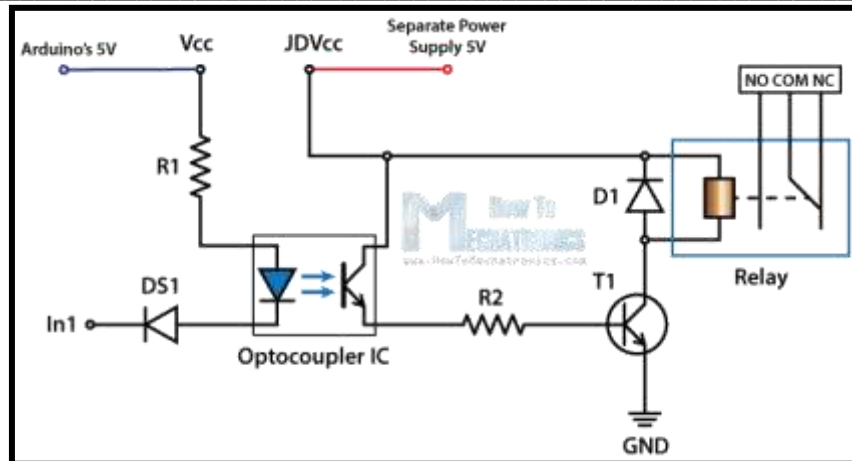

FIGURE 2: Circuit diagram of AC motor controller switch

III. PROPOSED METHODOLOGY

We are designing and fabricating Automatic Dustless Chalk Making Machine by using ECU. The basic structure hopper, electric motor, mould, stepper motor and ECU mounted on the frame. When the chalk mixture pours in the hopper, it is mixed in the hopper with help of blades for the definite time. The mixture is then poured into the mould and excess material is wiped out by slider which is connected to stepper motor. The heated water circulated around the mold and dries the mixture in the mould. The mold slides towards second station with the help of slider. At the second stage the ejection process takes place where ejector pushes the chalks out of mould with the help of stepper motor. All these processes are done automatically and controlled by ECU.

3.1 Steps for design and fabrication of machine

The Design and Fabrication of our Automatic Dustless Chalk making Machine is carried out in following steps –

3.1.1 Designing of structure and components

The first step is to design the frame which is the main structure of machine on which all the other parts are to be mounted. The stresses and vibrations are to be calculated which are going to act on the frame and the vibrations produced needed to be damped so the machine has to be designed to absorb vibrations produced. Some of the components which are not available in the market are to be designed and analysed so that they do not fail during operation.

3.1.2 Ordering the designed parts

Second step includes the parts which are needed for the design and fabrication of the machine and are available in the market has to be ordered because of their standard size such as nuts and bolts, electrodes for welding, Arduino Mega, stepper motors, threaded rods, motor coupling, linear bearings, frame material, etc.

3.1.3 Fabricating the structure

Third step is to make the actual frame from the material ordered. In this step the material has to be cut according to the sizes required, welded where ever needed and bolted for the maintenance purpose. After the frame is ready it will have to be checked for any failure before installing other parts such as electronic components, mould, ejector and hopper.

3.1.4 Designing of mould

The next step is to design a custom mould for 220 chalks in one batch of dimensions (180mm×180mm×70mm). And for heating the mould, holes of ½ inch diameter are to be drilled through it and in to the surrounding surface area so that heating effect is achieved for all the chalks. The material of the mould is to be of high thermal conductivity so that heat flow rate is maximum.

3.1.5 Assembling of Parts

After the frame is setup the next part is to assemble all the other components of machine such as AC motor for mixing, Hopper, Stepper motors, Stepper motor relay, Ejector, Mould and chalk tray for collecting the produced chalks.

3.1.6 Programming the Electrical Control Unit (ECU)

The sixth step is to program the Arduino Mega for controlling all the electrical components such as stepper motor, AC motor, distance sensors, temperature and humidity sensors, Servo motor as per the requirement of the processes.

3.1.7 Testing the machine for the objective to be achieved

After the program is uploaded to the Arduino Mega the next step is to check the working of all the electrical components like direction of stepper motors, temperature sensor reading the room temperature as well as hot water, working of servo for required angle, display screen displaying all the processes currently running on, the ejector ejecting the chalks after they are dried.

3.1.8 Checking the quality of product produced

The last step is to check the quality of the chalks produced by the machine. The dryness achieved by the heating system. The length of the chalks are equal so that further processing is not needed like slicing.

IV. CONCLUSION

We will be designing and fabricating the Automatic Dustless Chalk Making Machine. To do so we went through various research papers which helped us to understand the mechanisms and processes to fabricate the machine. As we get to know the main drawbacks of traditional machines in the market is high lead time and low productivity, we concentrate on reducing manpower, lead time and increasing the productivity. By using the stepper motors and electrical control units for automating the chalk making machine and also a heating system embedded in the project to reduce the drying time of the chalks. We have even designed mould and ejectors on the 3D model software.

REFERENCES

- [1] Abdurrahman, M.B. Obi, A.I. Baba M.T, "Design, construction and commissioning of a Chalk Extrusion machine", International Journal of Scientific & Technology Research, Vol. 2, 2013, pp. 302-304.
- [2] Mrs. G. Udayshree, Mr. V. Ratnakiran, "Design and modelling of mechanisms used for chalk manufacturing in semi-automated chalk making machine", International Journal of Mechanical Engineering, Vol 3, 2015 pp. 22-25.
- [3] I.G Davou Chomo, L.I. Pam, Z.S. Johnson, "Design, Construction and Testing of a Chalk Moulding Machine", International Journal of Academic Engineering Research, Vol 2, 2018 pp. 1-5.
- [4] Rajendra S. Thakur, Jignesh J. Shukla, "Understanding the factors influencing quality of writing and wiping for chalk and board system", Current Science. Vol. 112, pp. 1727-1737.
- [5] R. HariSudhan, M. Ganesh Kumar, "Arduino ATMEGA-328 Microcontroller", International Journal of Innovative Research in Electrical, Electronic and Control Engineering, Vol. 3, 2015 pp. 27-29.
- [6] SwapnilPatil, Ramesh Patil, "Controlling stepper motor using Arduino UNO", International Research Journal of Engineering and Technology, Vol. 5, 2018 pp. 3540-3542.
- [7] Joana Noble, Karl Walczak, "Rapid Tooling Injection Moulded Prototyping", Science Direct, Vol. 14, 2014 pp. 251-256.
- [8] Ravi Waswani, AakanshaPawar. "Induction motor fault detection, protection and speed control using Arduino", International Conference on Innovations in Information, Embedded and Communication Systems, 2015 pp. 1-5.
- [9] Nathan David, AbaforChima, "Design of Home Automation System using Arduino", International Journal of Scientific & Engineering Research, Vol 6, 2015 pp 795-801.
- [10] R Krishan, "Selection criteria for Servo Motor Drives", IEEE Transactions on Industry Applications, Vol 23, 1978 pp 270-27.