

Implementation of Thyristor Switch Capacitor for Improving Power Factor

Ronak Gohil¹, Dhaval sojitra², Nikhil Lunagariya³, Chitralkha Vangala⁴

¹ Department of Electrical Engineering, Viva Institute of Technology, Virar, Maharashtra (India)
Email: 17401070ronak@viva-technology.org

² Department of Electrical Engineering, Viva Institute of Technology, Virar, Maharashtra (India)
Email: 17401056dhaval@viva-technology.org

³ Department of Electrical Engineering, Viva Institute of Technology, Virar, Maharashtra (India)
Email: 17401072nikhil@viva-technology.org

⁴ Department of Electrical Engineering, Viva Institute of Technology, Virar, Maharashtra (India)
Email: chitralkhavangala@viva-technology.org

Abstract— Electricity is one of the most important blessings that science has given to mankind. Efficient generation of power at present is significant as wastage of power is a major issue. In most of power systems, a low power factor occur due to increasing use of inductive loads is often overlooked. A power factor improvement device would help the system to increase its power factor near to unity for energy saving & economical operation. Our project mainly focuses to build an TSC (Thyristor Switch Capacitor) to improve the power factor in leading as well as lagging condition by use of capacitor bank. We are implementing the circuit project as per the new rule by MERC (Maharashtra Electricity Regulatory Commission) which will be implemented from April 2020.

Keywords— Power factor, Capacitor bank Arduino, Micro-controller, TRIAC, Load.

I. INTRODUCTION

We can define power factor as the ratio between the KW active power and the KVA apparent power drawn by an electrical load. The higher the p.f. of a system the more economically it operates. A low power factor can be the result of a significant phase difference of voltage and current. Generally it is the use for non resistive load such as induction motor, power transformers or induction furnaces that causes a current to reduce power factor. A low power factor resulting from inductive loads can be improved by power factor improvement methods.

All inductive loads require active power to perform the actual work, and reactive power to keep the magnetic field constant. Power factor correction is the method to compensate a lagging current by a leading current through connecting capacitors to the load side. Capacitors contained in various power factor improvement device draws current that leads voltage and produces a leading power factor, hence improving p.f.. A sufficient reactive power banks is installed so that power factor is kept as close to unity (1).

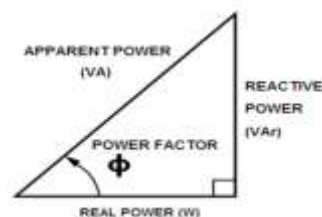

FIGURE 1: Power Triangle

A load with a p.f. near to 1 that is unity result in the most effective use of the supply and a load with lagging of power factor of 0.8 will increase losses in the supply system and resulting increases the maximum demand. Low load phase angle is generally happens due to an inductive load such as an induction motor, power transformer or, lighting ballasts etc .

This paper presents the implementation of TSC. The proposed system uses capacitor Bank to compensate the lagging power factor of load. Capacitor Bank are energized through TRIACs whose switching is controlled by an Arduino board. The Arduino board its program to continuous monitoring the power factor of the connected load and initiate the to operate of company capacitor bank through TRIAC if the load power factor is below reference value.

II. MATERIAL AND METHOD

2.1 REASONS OF LOW POWER FACTOR

- Mercury vapour lamps or lamps operated with chokes
- Power and distribution Transformers. A complete unloaded transformer is very inductive and has a very low power factor.
- Induction motors (Load and unload condition)
- The inductive load equipment causing low power factor in the mines includes Hoists, Shovel, Drill, Pump, Shearer, Conveyors etc.

2.2 POWER FACTOR CORRECTION

Power factor improvement is a technique of eliminate the undesirable effects of electric loads that create a power factor that is in lagging .Capacitive Power Factor correction is applied to circuits which include inductive load as a means of reducing the inductive component of the current and there by increase the efficiency of the system.

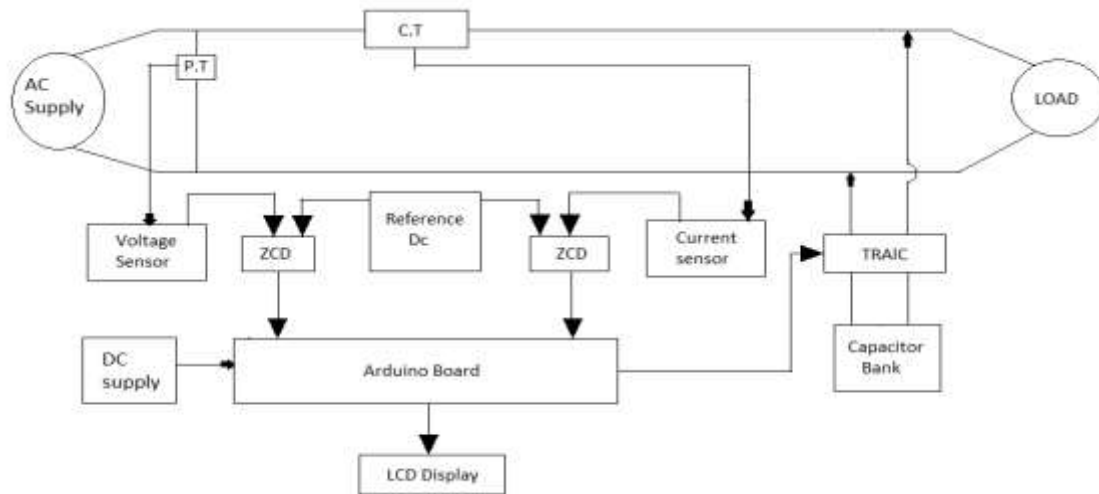

FIGURE 2: Block diagram of TSC

2.3 DESIGN

Motor input = KW(kilo watts, Old P.F = $\text{Cos}\theta_1$, Required P.F = $\text{Cos}\theta_2$)

Capacitor required

$$\text{kVAR} = \text{KW} (\tan\theta_1 - \tan\theta_2)$$

We know that; $IC = V / XC$

Where. $XC = 1 / 2 \pi F C$

$IC = V / (1 / 2 \pi F C)$

And, $kVAR = (V \times IC) / 1000 \dots [kVAR = (V \times I) / 1000]$

We have now calculated the required reactive power in kVAR, now we can easily calculate the rated capacitor by a simple formula

Required Capacity of Capacitor in Farads/Microfarads.

$C = kVAR / (2 \pi f V^2)$ in microfarad

2.4 WORKING

The TSC stands for Thyristor switched capacitor. It is an device used for the compensating the reactive power in the electrical power system. Its consists of a capacitor which is in series connected to the TRIAC valve, and also it has the reactor or an inductor.

The proposed system takes 230 volts, 50 hertz main supply as a power source and step down the voltage level to 12 volts through a PT. The power supply unit then convert this 12-volt AC into two different DC power and systems of + 9 volt and + 5 volt. The sample voltage signal is obtained from this 12-volt AC signal and process through the voltage sensor circuit for arduino UNO. A current signal sample is also obtained from the main supply by a current transformer and processed by a current sensor circuit for another Arduino UNO. The microcontroller performs power factor calculation and provide gate pulse to TRIAC and switch on capacitors from the bank result are displayed on a LCD display. The functional block diagram of the complete project is shown above.

The whole TSC unit consists of 8 power factor correction modules given as follows:

- 1) Power supply
- 2) Voltage sensor circuit
- 3) Current sensor circuit
- 4) TRIAC
- 5) Arduino
- 6) Inductive load
- 7) Display
- 8) Capacitor Bank.

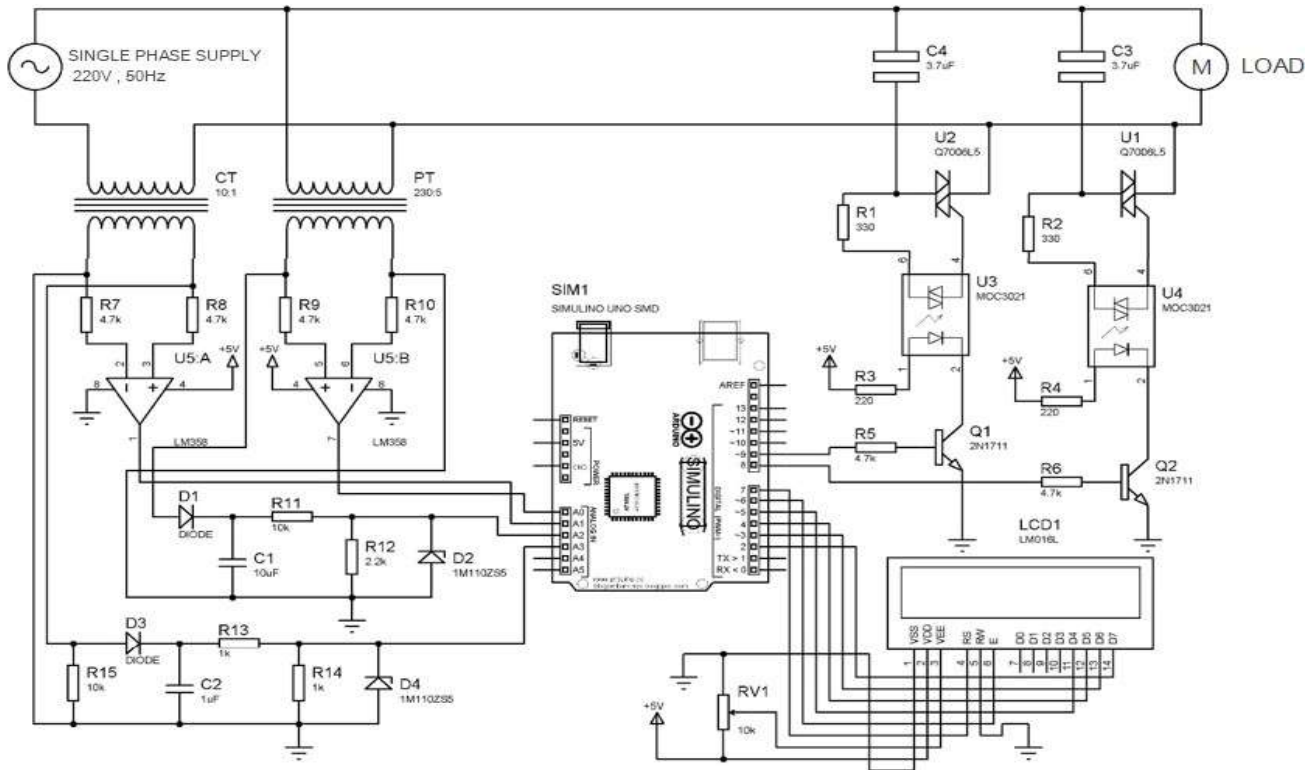

FIGURE 3: Circuit Diagram of Thyristor Switched Capacitor (TSC)

2.5 ALGORITHM

- Step-1: Take input for voltage and current in the circuit.
- Step-2: Measure the phase lag and calculate the power factor.
- Step-3: Differentiate from the targeted power factor and calculate the reactive power requirement.
- Step-4: Switch ON or OFF appropriate number of capacitors from capacitor bank depending on reactive power supplied by each step.
- Step-5: Again compare the power factor with targeted PF and continue from step-1.

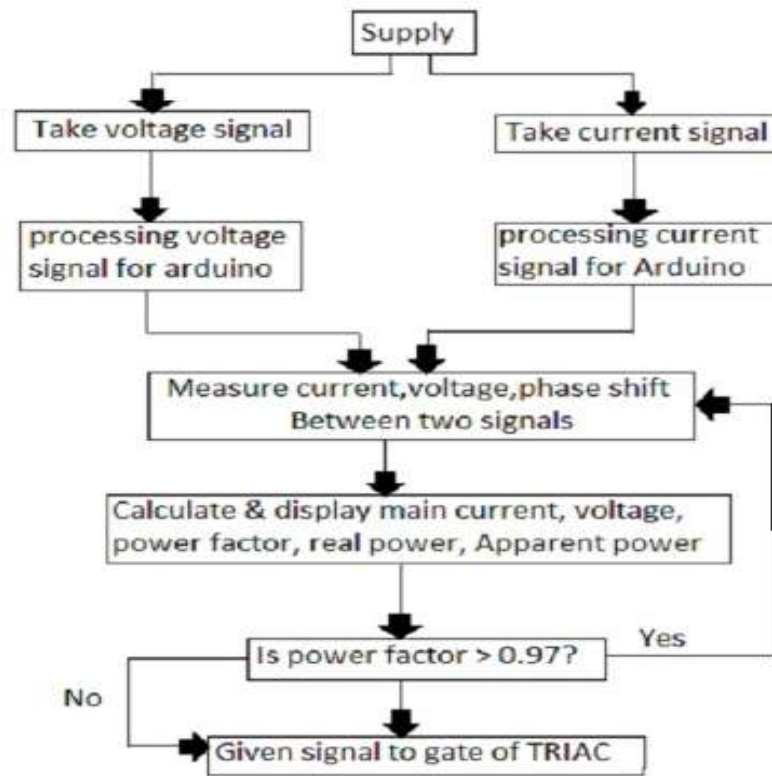

FIGURE 4: Flow chart of system

2.6 ADVANTEGES

Using this device, we can avoid the penalty on utility bills and can also gain incentive to reduce the cost of overall bill. It also reduces the contract demand charge.

Due to improvement in PF we can minimize the line current due to which the losses are reduce, hence resulting in improving the system efficiency. Increase the load carrying capacity in the existing circuit, hence increasing the lifespan. Improving PF leads to improving to voltage at the load.

III. CONCLUSION

This project provides better techniques used to overcome the power losses due to low power factor in industrial units. The acceptable results of the proposed TSC system operation indicate the power factor correction by means of TRIAC switched capacitors in economical methods to overcome the power loss in distribution side due to lower PF associated with the electric load as well as good means to reduce the electricity bill.

FUTURE SCOPE

The automatic power factor improvement using capacitive banks is very efficient as it reduces the cost by decreasing the power wasted from the supply. It is an automatic process so manpower required is less and this Thyristor Switched Capacitor can be used to improve power factor.

REFERENCES

- [1]. [978-1-5386-9425-1/2018/IEEE] Automatic power factor correction for single phase domestic load by means of Arduino based TRIAC control of capacitor banks.
- [2]. [10.1109/ICECCT.2017.8117969/ Research Gate] Automatic power factor correction & energy monitoring system.
- [3]. [978-1-5090-1252-7/2016/IEEE] Automatic power factor correction unit
- [4]. Automatic power factor improvement using microcontroller[978-1-4799-6908-1/2015/IEEE]
- [5]. Transmission system reactive power compensation, B. F. Wollenberg Minnesota Univ., Duluth, MN, USA, Date of Conference: 2002 Page(s): 507 - 508 vol.1 Print ISBN:0-7803- 7322-7, INSPEC Accession Number: 7386352, DOI:10.1109/PESW.2002.985054, Publisher: IEEE
- [6]. T.J.E. Miller, "Reactive power control in electric systems" (New York: John Wiley & Sons, 1982).
- [7]. "Concepts of Reactive Power Control and Voltage Stability Methods in Power System Network" IOSR Journal of Computer Engineering (IOSR-JCE) e-ISSN: 2278-0661, p- ISSN: 2278-8727Volume 11, Issue 2 (May. - Jun. 2013), PP 15-25 , Akwukwaegbu I. O, Okwe Gerald Ibe
- [8]. senior member, IEEE, "Reactive Power Compensation Technologies: State-of-the-Art Review" Proceedings of the IEEE, VOL.93, NO.12, december2005, Juan dixon,
- [9]. "The Research on Reactive Power and DC Bias Compensation", IEEE Electrical Machines and Systems (ICEMS), 2011 International Conference Beijing, Aug 2011. Baodong Bai, Zhijia Zhang, Bo Kang, Dezhi Chen.
- [10]. P. N. Enjeti and R martinez, "A high performance single phase rectifier with input power factor correction ,"IEEE Trans. Power Electron..vol.11,No.2,Mar.2003,pp 311-317 "POWER FACTOR CORRECTION." www.nhp.com.au. NHP Catalogue - PFC-SFC, Nov. 2007. Web. 14 July 2016. Available at [https://portal.nhp.com.au/power-quality]
- [11]. ["POWER FACTOR CORRECTION." www.nhp.com.au. NHP Catalogue - PFC-SFC, Nov. 2007. Web. 14 July 2016. Available at [https://portal.nhp.com.au/power-quality]
- [12]., "Reduced conduction loss zero-voltage-transition power factor correction converter with low cost,"IEEE Trans.Industrial Electron..vol.45,no 3,Jun. 2000,pp395-400, J.G. Cho,J.W. Won,H.S. Lee.