

## Study of LED SPINNER

Aditya Shirke<sup>1</sup>, Ajit Shinde<sup>2</sup>, Abhijit Biswas<sup>3</sup>, Pratik Parsewar<sup>4</sup>

<sup>1</sup>Department of Electronics and telecommunication, Mumbai University, Virar -401 303

Email: shirkeaditya30@gmail.com

<sup>2</sup>Department of Electronics and telecommunication, Mumbai University, Virar -401 303

Email: ajit15shinde@gmail.com

<sup>3</sup>Department of Electronics and telecommunication, Mumbai University, Virar -401 303

Email: abhibiswas1224@gmail.com

<sup>4</sup>Department of Electronics and telecommunication, Mumbai University, Virar -401 303

Email: pratik.parsewar@gmail.com

**Abstract**—Notice board is a primary thing in any institution or organization to spread information among stakeholders. In today's busy and fast moving world, the traditional glued paper notice system is time consuming and not suitable for quick exchange of information. The letter represents a smart electronic remote noting system where an authorized accountable person can share information in an information board in their office room or cellular network at any time from any place in the world. In the proposed system, notice can be sent in two ways. The user can update the notice from his office room by voice or text message via smart phone using Bluetooth and RF communication within a distance of 1 kilometer. In this way, the user sent a notice using their own wireless network and should not pay money to any operator.

**Keywords**—Matrix Display, Bluetooth Module, Transceiver, microcontroller.

### I. INTRODUCTION

If we have to show an important notice in colleges and anywhere else, we can use these LED display. This smart noticing system can be a very useful media for quick sharing of information in various small as well as a large organization. It can also use in railway platforms for showing trains arriving on different platforms it will also help to deaf and dumb people to know the important announcement on the LED display boards. It can control by smart phone from anywhere in department and even from your native places. It can use in mass media sector as a digital script for an actor, for a news reporter, for a speaker, etc.

The objective of the research is to develop a wireless electronic display board improving the previous limitations to make the noticing system easy, fast, secure and cost-effective. We can use these featured LED display anywhere like on railway platforms, mall. The system is password protected, very easy to operate and operating cost is small as most of the time user can send notice by local RF wireless network without using the mobile network. Our scope is to make it handier and very effective for today's generation who believes in smart work rather than hard work.

### II. MATERIAL AND METHOD

The vending machine proposes a simple design to vend the medicines with high accuracy and brings the objective to provide automation in the medical field. Automation deals with the reduction of human effort using electronics motors, sensors and components having mechanical mechanisms. It includes three simple stages select(input), pays and collect (Output). Here the inputs are given by LCD which is controlled by different switches and different sensors to take the readings. This machine has two options two dispense the medicines. A first option is a direct option that will direct dispense the medicines as per selection. In second option machine asks some queries to the consumer extract the keywords from response to that queries as input, also takes the reading from heart rate sensors and temperature sensors and finally proceeds the current data using a machine learning model to dispense the medicine with high accuracy.

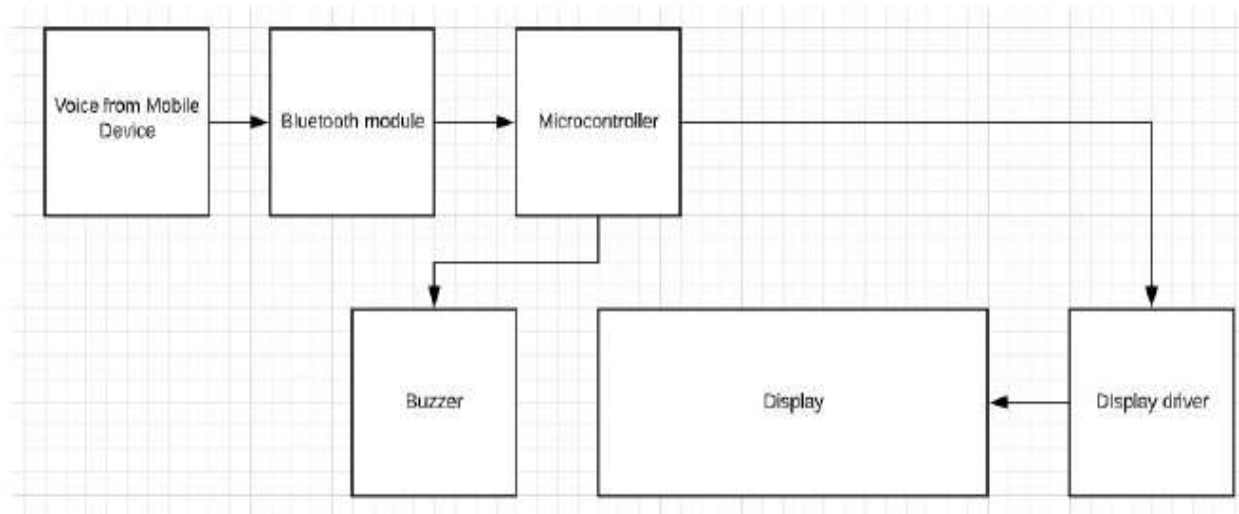

**FIGURE1: Block Diagram of LED Spinner**

## 2.1 Proposed methodology

Proposed methodology involves the procedure to design the medicinal vending machine which consists of different sensors, motors, LCD display, and main microcontroller. This paper proposes the use of raspberry pi as its main CPU which monitors the motors used to dispense the medicine and has interfaced sensors with it which will allow taking readings from the consumer. This reading will be updated on the cloud and displayed on the LCD display.

The queries will ask using this display and using switches consumers can answer to those queries. After the selection, the machine will ask the user to stick the sensors on the tip of the finger or limbs of the hand using the Velcro tape. Regarding instructions about the time will be provided to the user through a display. Since it is not feasible to wore sensors for more than one minute but to increase the accuracy of the data from sensors, this paper suggests to wait for 30 seconds. After the collection of data, this data will feed to the machine learning model as input and based on this data which contains extracted keywords, temperature and heart rate sensors then it will lead to dispense the according to medicine.

In this, 16X2 LCD display is interfaced to raspberry pi with its GPIO pins. It has 16 pins out of which 4 pins are interfaced with GPIO ports to display the required character on the screen, also pin register select (RS) and enable is interfaced to GPIO pin and there are Vcc and ground at pin number 2 and 1 respectively. All sensors and display work on the 5V power supply. Pulse rate sensor can be operated at both +5V and +3V power supply. It consists of three pins for ground, Vcc and pulsating output signal. This sensor has two sides, on one side there is the light sensor is present where the tip of the finger should be placed and another consist of some circuitry for noise cancellation purpose. Temperature sensor MAX30205 is used to sensor temperature which offers  $\pm 0.1^{\circ}\text{C}$  (max) accuracy which meets thermometry specifications. This will provide high accuracy with more efficiency.

To vend the medicine the dc motors with spring mechanism is used. After the appropriate signal, the motor will rotate the spring through 360° clockwise to vend the medicine. But the dc motors are operated at 12V power supply and we get only 5V of power supply from raspberry pi. Hence, this paper suggests using a relay circuit to step up the voltage for the operation of the dc motor.

## 2.2 Internal architecture

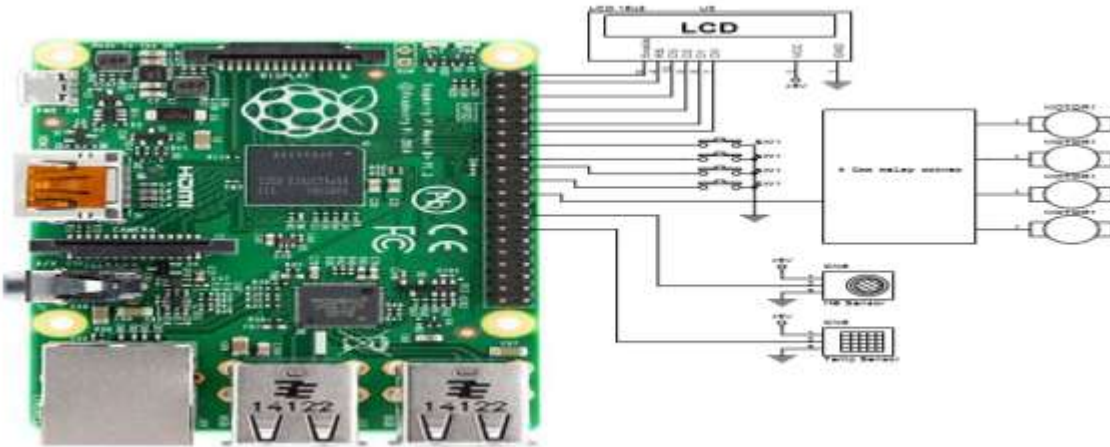

**FIGURE 2: Internal Architecture of LED Spinner**

## 2.3 Decisionmaking tree:

A decision tree is a tree-like graph in which the nodes represent the place where we select an attribute and ask a question; Edges represent the answer to the question and the leaves represent the class label. They are used in non-linear decision making along the surface of simple linear decision making. For example, categorize the class by sorting on some leaf node as the root of the tree. Each node of tree serves a test case for some properties, and each edge from that node corresponds to a possible answer of test case. This process is recursive in nature. It is also repeated for each sub-tree for new nodes.

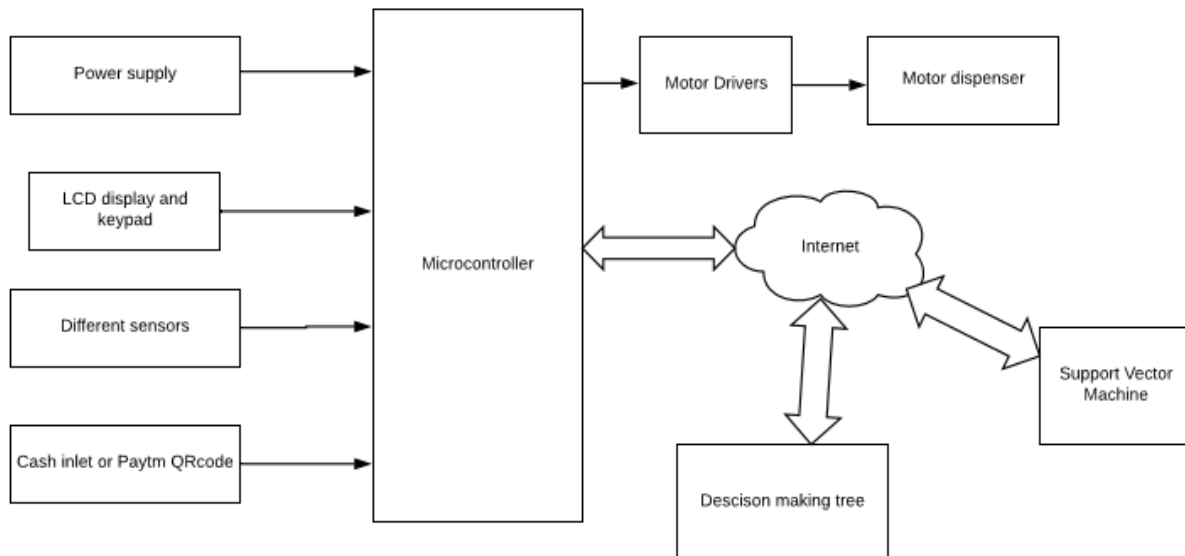

**FIGURE 3: Block Diagram**

## 2.4 SVM:

“Support Vector Machine” (SVM) is a supervised machine learning algorithm which can be used for both classification or regression challenges. However, it is mostly used in classification problems. In this algorithm, we plot each data item as a point in n-dimensional space (where n is number of features you have) with the value of each feature being the value of a particular coordinate. Then, we perform classification by finding the hyper-plane that differentiate the two classes very well.

## 2.5 Password Protection:

Bluetooth device used in the system is password protected. So unauthorized person cannot send any information in this display board. Following AT commands are used to configure Bluetooth device.

AT Command	Action
AT+ROLE=0	Bluetooth module is set as slave.
AT+UART=9600	Baud rate is set at 9600.
AT+PSWD=password	Set password of Bluetooth device.

## III. CONCLUSION

This smart noticing system can be a very useful media for quick sharing of information in various small as well as a large organization. The system is password protected, very easy to operate and operating cost is small as most of the time user can send notice by local RF wireless network without using the mobile network. Also, the responsible person has the option to share information with his employee or customers from any place in the world sending SMS from mobile. The system has some limitations too. It has no option to change the password, update time or date of notice is not shown automatically by the system, size of the display is small and data is shown in only one display (notice board). In future, these limitations can be resolved to make the smart noticing system more beneficial.

## REFERENCES

- [1] DjemaaBOUCHA, Ayoub AMIRI, Djillali, CHOGUEUR “Controlling Electronic Devices remotely by voice and Brain Waves”, 2017 International Conference on Mathematics and information Technology, Adrar, Algeria – December 4 - 5,
- [2] Ashfaquul Islam, Tonmoy Mohammad Fahim Hossain, Sayed Zubaer Hasan, “Voice, Gesture and IR Remote Controlled Alphabet Learning Display for Kids Based on 16X16 LED Dot Matrix Display.”, 2019 International Conference on Electrical, Computer and Communication Engineering (ECCE), 7-9 February, 2019
- [3] Md. Eftekar Alam, M.A. Kader, Shamima Akter Proma, Sanchita Sharma, “Development of a Voice and SMS Controlled Dot Matrix Display Based Smart Noticing System With RF Transceiver and GSM Modem.”, 2018 21st International Conference of Computer and Information Technology (ICCIT), 21-23 December, 2018
- [4] P.R. Naregalkar<sup>1</sup>, Chirag Nangia<sup>2</sup>, Arun Kumar<sup>3</sup>, Apoorv Raj<sup>4</sup>, “Voice Controlled L.E.D Matrix Display”, Vol. 6, Issue 3, March 2017
- [5] Sathis Vatumalai<sup>1</sup> and A. Oudah<sup>2</sup>, “Android-based Voice Activated Dot Matrix Display”, International Journal of Grid and Distributed Computing Vol. 9, No. 10 (2016), pp.53-64.
- [6] Philip Daum, Brent Fukuda, Nick Jensen, “Virtual Versus Real Design Of A Traffic Light/Voice Controller”, July 7 – 9, 2005, Juan Dolio, Dominican Republic ITHET 6<sup>th</sup> Annual International Conference.
- [7] R. Ranadheer Reddy, N Prashanth, G. Indira, M Sharada, “Electronic Scrolling Display Using Arduino Board”, International Journal of Engineering Research in Electrical and Electronic Engineering (IJEREE) Vol 4, Issue 2, February 2018.