

# Power Grid Monitoring and Controlling By Using Internet of Things (IoT)

Mr. Suhas Pawar<sup>1</sup>, Mr. Chinmay Patil<sup>2</sup>, Mr. Hardik Dhanu<sup>3</sup>

<sup>1</sup>Department of Electrical Engineering, Viva Institute of Technology, Virar  
Email: pawarsuhas016@gmail.com

<sup>2</sup>Department of Electrical Engineering, Viva Institute of Technology, Virar  
Email: chinmaypatil05@gmail.com

<sup>3</sup>Department of Electrical Engineering, Viva Institute of Technology, Virar  
Email: hardikdhanu06@gmail.com

**Abstract**— This paper presents a review of monitoring and controlling electric load in Power Grid by comparing different methods of implementation of this technology. In the power grid, people are finding various efficient resources. So power is the main concern which needs to be monitor and control. In this paper, a model is a design that aims to control and monitor the power consumption of a particular area or power grid line. The objective of this paper is to design microcontroller atmega328p connected to different sensors such that current and voltage measurement sensor, Wifi module sensor for monitoring and controlling a power grid system problems. This design model monitors the power consumption of the end-user and cuts off the power supply when it exceeds the set limit. The device sends the power consumption data to the suppliers web server using the internet of things (IoT) technology.

**Keywords-** Power Grid, Internet of things (IoT), atmega328p, current and voltage sensor, Wifi module.

## I. INTRODUCTION

Conservation of energy is a very important need of the day. The concept of electrical energy efficient devices has come up in various sources such as lighting, air conditioning and so on. Electrical energy monitoring is an important tool for determining the energy efficiency of various equipment and devices. This paper implements an energy monitoring system that displays the power consumed. This can help a user to detect any fault in the power system. A smart energy monitoring system can help a user to analyses the energy consumption data at the device level and manage it assuming it to be fixed monthly rates. Also, it helps a consumer to replace the regular appliances by energy efficiency. The monitoring system can inform and alert the user on unexpected excess power consumption caused by equipment faults, lack of proper maintenance and system behaviors. Further, proper electrical energy management can make proper budgeting possible.

Internet of things has opened up a platform of applications in various fields such as medical, automation systems, healthcare systems, smart home automation, and power monitoring. IoT is expected to bring about a large number of changes in the field. IoT based energy management systems can give a lot into the conservation of energy. Energy bills are generated monthly and the user has the option of analyzing the consumption details every month and yearly. The energy meter installed in the residential buildings, commercial buildings show the energy consumed by the household. Very often, devices which operate in standby mode consume an efficient amount of power about which the end customer is unaware of. So, there is a very strong need for a novel energy monitoring system that can show the energy consumption of different devices and equipment in normal as well as standby backup mode and also alert the user on an unexpected rise in energy consumption on daily basis.

## II. CURRENT SCENARIO AND TECHNICAL CHALLENGES

### 2.1 CURRENT SCENARIO

The current energy scenario has introduced different technical challenges to be solved such as the integration of clean electrical energy generation and the use of efficient high-power and energy storage systems. The electrical power energy industry has to face the problems in terms of reliability and stability of the power grid. Also, energy distribution systems based on the HVDC

topology are being installed and online monitoring, controlling are possible all over the world. On the other hand, it becomes extremely most important to use energy storage systems to stabilize and improve the energy efficiency of the power systems using ultimate generation storage batteries, ultra-capacitors based systems, and mechanical systems, among others. Nowadays, the power devices efficient solutions to be applied to the new distributed energy grid concept. This paper briefly reviews the current scenario where power electronics converters and the internet of things are being applied. The main on the energy systems, the energy storage, Data management systems, and the high electrical power applications, reviewing the different alternatives and topologies, already as industrial products or still as research lines.

## 2.2 TECHNICAL CHALLENGES

1. Inadequacies in grid infrastructure
2. Cyber security
3. Storage concerns
4. Data management
5. Communication issues
6. Stability concerns

## III. BLOCK DIAGRAM

The Power Grid System consists of basic blocks mainly the Current sensor and Voltage detector, A2D convertor, Microcontroller, 12V & 5V DC supply, Buzzer, Relay Switch, LCD Display, WiFi module, Cloud, Interface block. This is diagrammatically shown in figure 1

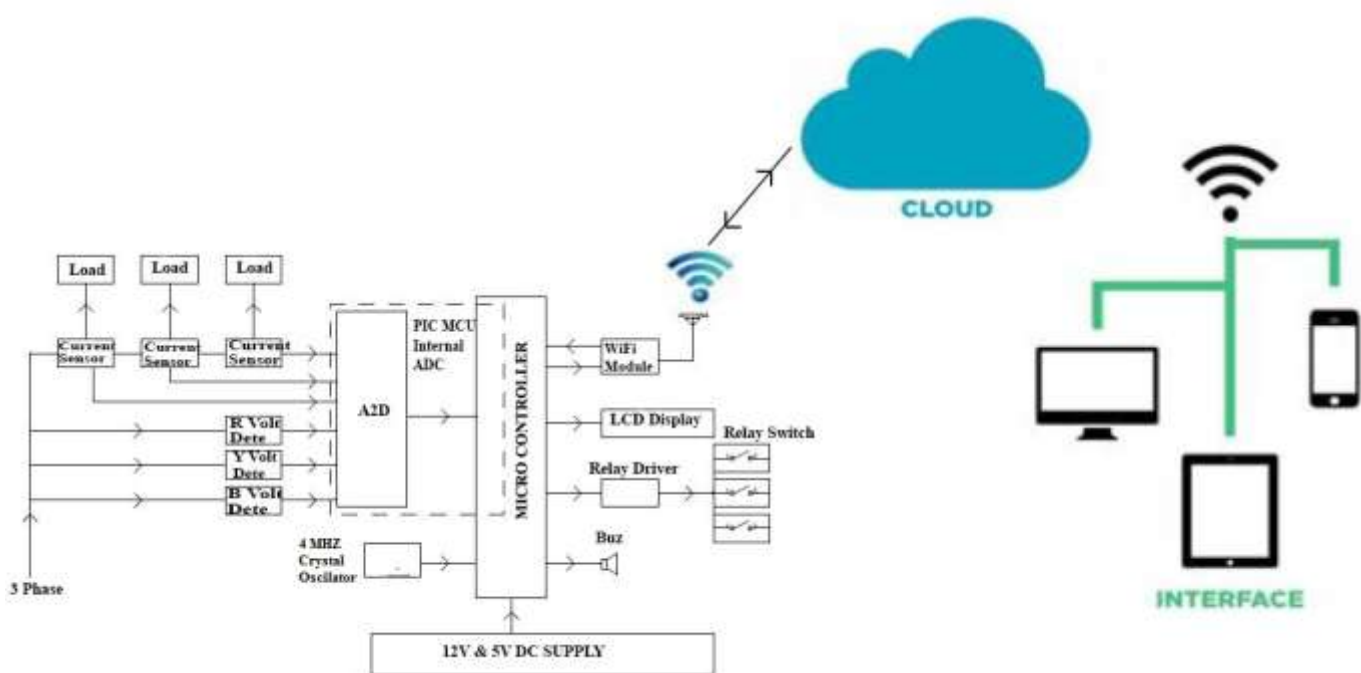

**FIGURE 1: Block diagram of power grid monitoring and controlling by using IoT**

#### IV. CIRCUIT DIAGRAM, WORKING, COMPONENTS DESCRIPTION

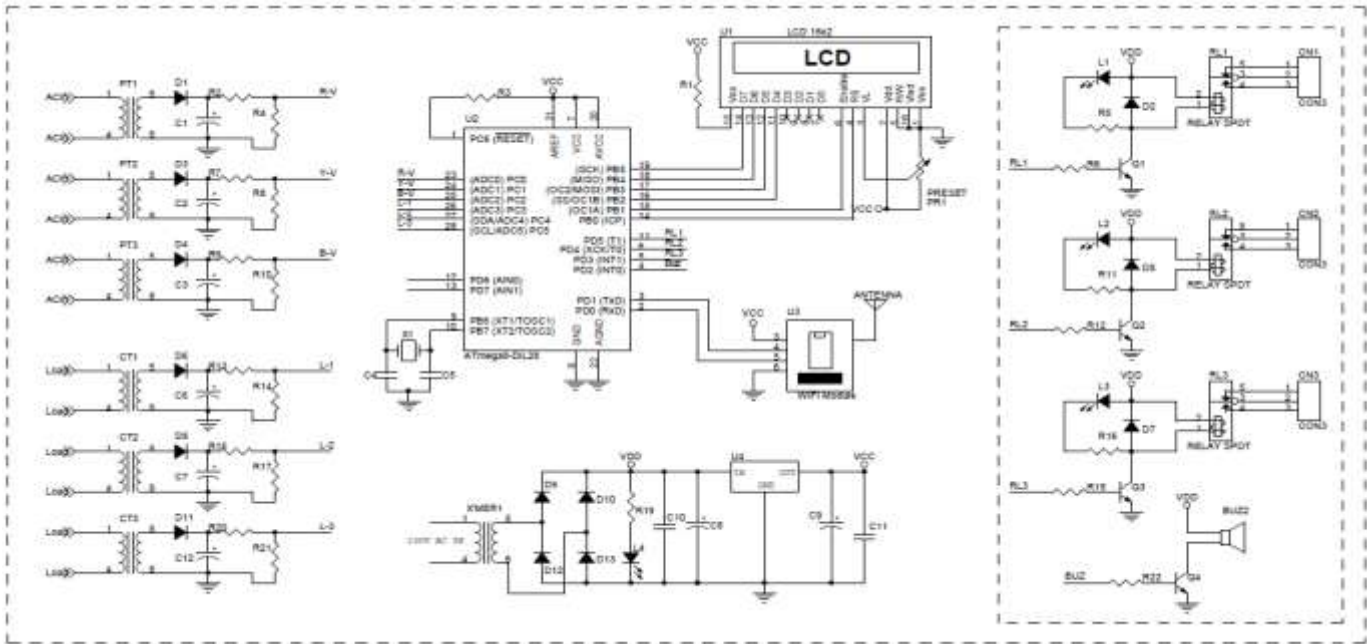

**FIGURE 2: Circuit diagram of power grid monitoring and controlling by using IoT**

#### 4.1 Working

Block diagram above in Fig 1 is designed to operate in two modes. The power supply is turned ON, the microcontroller Atmega 328p and relays driver is required 5V & 12V DC supply. So by use of a step-down transformer, the Rectifier circuit to give required supply to all interface components get the required supply. The three-phase supply is fed to load by using contactor to controlling the load. In between three-phase line and load the voltage, current, zero crossing detector sensors are connected for sensing different parameters. In microcontroller write program for calculating all parameters like voltage, current, active power, reactive power, apparent power, pf, etc. All this parameter receive by three-phase main lines and load side sensors. The microcontroller reads the data from various sensors in digital digit by using A2D converter and analyses according to the given instructions, Microcontroller reads the commands from the internet and provides control signals to the relay via a three-phase contactor, which will control the Load. After the microcontroller, process on that data, the load control is based on automatic and manual mode the control is based on the sensed parameters is received an alert from the sensors and display indication on LCD or alert via a buzzer. The sensor information is displayed visually in the server in the cloud web page.

#### 4.2 Components Description:-

##### i. ATMEGA328P Microcontroller

ATmega-328 is basically an (AVR) Advanced Virtual RISC micro-controller. Its supports the data up to eight (8)bits. ATmega-328 has 32KB internal built-in memory. This micro-controller has a lot of other characteristics. ATmega-328 is mostly used in Arduino.

**ii. Power Supply**

The power supply circuit. It's based on three terminal voltage regulators, which provide the required regulated +5V and unregulated +12V. Power is deliver initially from standard 12V AC/DC adapter or 12V\_800ma Transformer.

**iii. ESP8266 (WI-FI Module)**



**FIGURE 3: ESP8266 WiFi module**

It is a low cost chip with TCP-IP stack and microcontroller. In our project main importance role of wifi is it performs IOT operation. The simple device is connected from microcontroller to send the information wireless.

**iv. LCD Display**



**FIGURE 4: 2\*16 LCD Display**

LCD (Liquid Crystal Display) is the technology used for displays in notebook, TV & other appliances. Like LED and gas-plasma technology, LCDs allow displays to be much thinner than cathode ray tube (CRT) technology. It displays the Energy Meter reading units and balance. A 16X2 LCD is connected with microcontroller at 7,8,9,10,11 and 12 pins to display the reading of various sensors.

**v. Relay**

Single pole double throw (SPDT) relay is connected to port RB0 of the micro controller through a driver transistor (Q1). The relay requires 12 V at a current of around 100 mili amps, which cannot provided by the micro controller. So the driver transistor is added. A relay is an switch that uses an electromagnet to move the switch from the off to on position instead of a moving the switch. It takes relatively a small amount of electrical power to turn on a relay but the relay can control something that draws much more power. The relay is used to operate external electronic lock, safety switch or any other electrical device ETC.



**FIGURE 5: Relay**

#### **vi. Contactor**

The contactor is an electrically controlled relay (switch) circuit used for switching an electrical power circuit by controlled power on and off. A contactor circuit has a much lower electric power level switched circuit, such as a 24V coil electromagnet controlling a 230-volt motor switch. Relays tend to be of lower capacity and are usually design for both normally closed (NC) and normally open (NO) applications. Devices switching more than 10-15 amperes or in circuits rated more than a few kilowatts and above are usually called contactors. Unlike relays, contactors are design with the features to control and suppress the arc produced when interrupting heavy currents and protect the system. Contactors come in many forms with varying rated capacities and features. Unlike a circuit breaker, contactor is not intended to interrupt a short circuit current (SC). Contactors range from those having a breaking current of sustained amperes to 1000 of amperes and 24 V DC to many kv. The contactors size is range from a device small to pick up with one hand, to large devices approximately a meter (yard) on a side. Contactors are used to control electric motors drives, lighting, heating, capacitor banks, thermal evaporators, and other electrical loads etc.

### **V. CONCLUSION**

In this project the concept of Internet of Things for early fault detection, monitoring, controlling of 3 phase load. The system has the ability to combine various sensed parameters in real time and improve accurate detection of different faults occur in load side. The monitoring of the lamp load system presents the measurement of different parameters namely p.f, supply voltage and current, frequency, real powers, reactive power, apparent power. The compared to other conventional methods this system has more number of fields which enables alarm, alert messages and quick controlling. The concept of IoT is presented here for remote monitoring and controlling the loads. The data is also displayed serially. The application of the system is needed today for all electrical system. The system has the specific advantage less maintenance, easy and quick controlling, monitoring and accessing of data remotely. Experimental results confirm the flexibility of the implementation of the system.

### **VI. FUTURE SCOPE**

The current day's mode of transmission and distribution of electricity has proven to be unreliable and inefficient. This is because the power smart grid technology currently in use has changed very little since it was developed. Researchers are now experimenting with smart grid technologies to overcome the shortcomings of the traditional grid. A power smart grid is a concept for transforming a power grid, with the modern networking communication, automated checks and other forms of information technology. It integrates new, innovative technologies of generation, transmission and distribution to home appliances and equipment. A power smart grid technology is an essential to provide easy integration and reliable service to the consumers. A power smart grid system is a self-sufficient electricity network system based on digital automation technology for monitoring, control, and analysis within the supply chain.

### **REFERENCES**

- [1] IOT Based State Estimate For Microgrid, Md Masud Rana, Wei Xiang and Eric Wang- Jan 2018 (IEEE Paper).
- [2] IOT Energy management Platform For Microgrid, Tai-Yeon Ku, Wan-Ki Park – 2017 (IEEE Paper).
- [3] IOT-Based Smart Grid System Design for smart home, Adi Candra Swastika, Resa Pramudita, Rifqy Hakimi, July 2017 (IEEE Paper).
- [4] Cloud Based Data Acquisition via IOT for Electrical Power Quality Monitoring, Velibor Pjevalica - May 2019 (IEEE Paper).
- [5] Application Of Internet Of Things In Smart Grid Power Transmission, Qinghai Ou, Yan Zhen, Xiangzhen Li- Jun 2012 (IEEE Paper).
- [6] Real time active power control in smart grid, Abdulfetah Shobole, Mohammed Wadi- Nov 2017 (IEEE Paper).
- [7] Active/Reactive power decomposition approaches to the AC optimal power flow problem, ByungKwon Park- Sep 2014 (IEEE Paper).
- [8] Design and Implementation of Wireless Power Monitoring System for Public Buildings! Shu-ping Le, Hong Zeng, Jian Qiu, Song Zhang 2013 (IEEE Paper)
- [9] A V-I slope-based Method for Flicker Source Detection, Alexandre B. Nassif, Student member, OCT 2005 (IEEE)



- 
- [10] Remote monitoring and control of smart grid power network system," The 40th International Conference on Computers & Industrial Engineering, Awaji, 2010 (IEEE)
- [11] Smart Power monitoring system using wireless sensor networks," 2012 Sixth International Conference on Sensing Technology (ICST), Kolkata, S.P.S. Gill, N. K. Suryadevara and S. C. Mukhopadhyay, 2012 (IEEE)
- [12] A new AMR approach for energy saving in Smart Grids using Smart Meter and partial Power Line Communication, Hammamet, Asma Garrab, Adel Bouallegue and Faten Ben Abdallah, 2012 (IEEE)