

Design and Fabrication of Temperature Controlling Mug by Using Peltier Effect

Darshan Dhanke¹, Nikhil Bhosale², Savio D'souza³, Shamu Chaudhari⁴

Department of Mechanical Engineering, MUMBAI University, Mumbai-400305

darshan.h.dhanke@gmail.com,

Department of Mechanical Engineering, MUMBAI University, Mumbai-400305

16101018nikhil@viva-technology.org,

Department of Mechanical Engineering, MUMBAI University, Mumbai-400305

saviodsouza1004@gmail.com,

Department of Mechanical Engineering, MUMBAI University, Mumbai-400305

shamuchaudhari1998@gmail.com,

Abstract— Now-a-days, every individual prefers to have beverages at their desired temperature. Due to the atmospheric conditions, any beverages tend to naturally approach to the room temperature. This causes a hindrance in maintaining the desired temperature of the beverage. There are various devices which help to maintain the desired temperature of the beverage. The devices available for maintaining the desired temperature are non-portable and support either active cooling or active heating. The proposed model is based on active cooling and active heating of the beverage according to the user's requirement. The model uses a principle of Peltier effect for maintaining the desired temperature. The model not only assists temperature variation but is also feasible due to its compact structure. It is a user friendly model which acts as a closed loop control system, that is, the temperature of the beverage is controlled by the peltier according to the user's requirement.

Keywords— Active Cooling, Active Heating, Peltier effect, Peltier module, Temperature Variation.

I. INTRODUCTION

The Peltier effect is the reverse phenomenon of the Seebeck effect; the electrical current flowing through the junction connecting two materials will emit or absorb heat per unit time at the junction to balance the difference in the chemical potential of the two materials. Thanks to this effect, an electronic refrigerator can be made, which is known as the Peltier cooler. The Peltier cooler has been applied to niche areas such as infrared detectors, CPU coolers, wine cellars, etc., because the cooling power is lower than that of compressor-based refrigerators.

1.1 PROBLEM STATEMENT

For cooling any beverage, refrigeration is one of the most common techniques, similarly heating a beverage also requires various equipment's but being non- portable in nature it becomes infeasible to carry it everywhere. Many devices provide either of the features that is, cooling or heating of the beverage. The proposed model helps to maintain the temperature of the beverage according to the user's requirement. It is a rechargeable portable device which can be easily handled. The model is user friendly equipment which allows the user to adjust the temperature of the beverage.

1.2 OBJECTIVES

The main objectives of the proposed model are:

- To provide Active heating and Active cooling of the beverage as per the users requirement.
- To develop a user friendly Portable unit that can be carried out by the user with ease.
- To maintain the temperature of the beverage as per the user requirement.

II. METHODOLOGY

To provide feasible and economical solution for the problem, a brief study and research work has been carried out in the following manner:

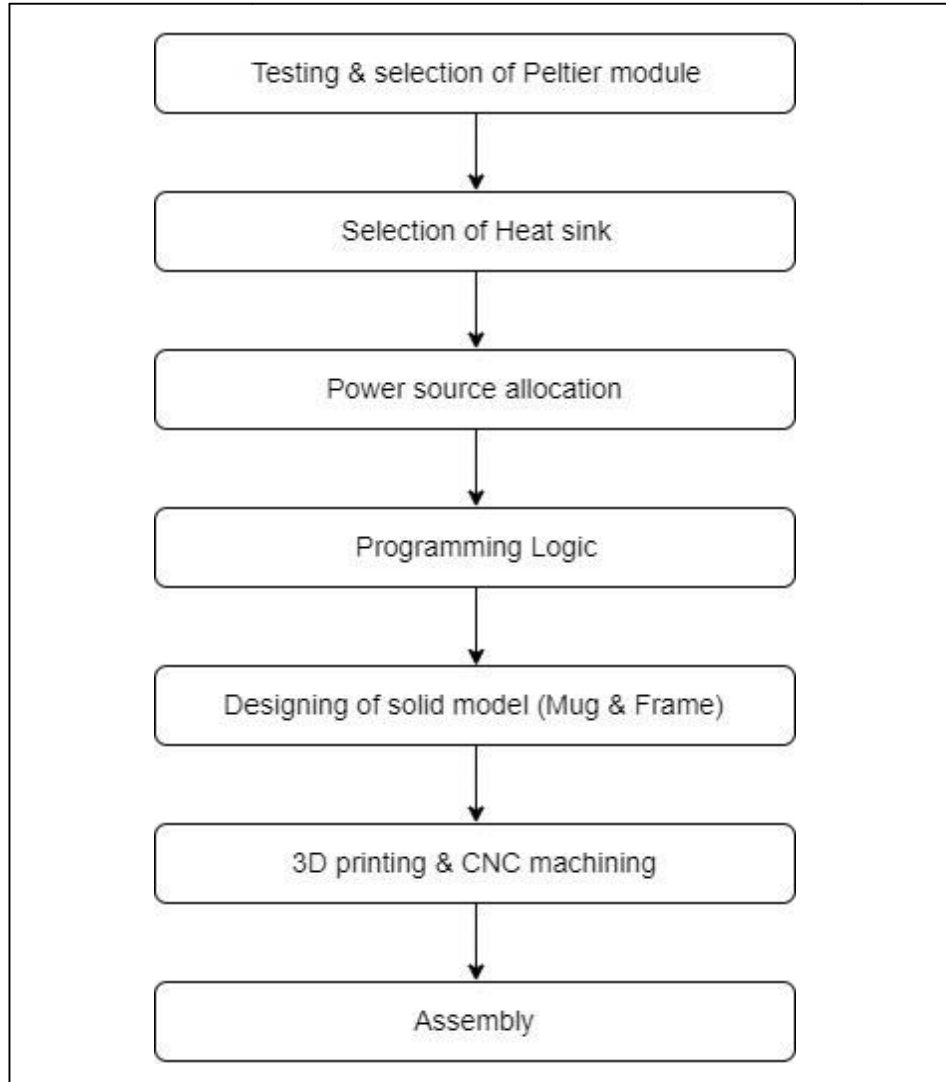

FIGURE2.1 System Methodology

- Testing & selection of Peltier module:

The selection of the Peltier module is based on higher rate of heat transferring between the two sides. It is also essential to have a lower rate of power consumption as the model has an independent power source which needs periodic charging. The last selection factor involves lower internal conduction in the Peltier plate.

- Selection of heat sink:

A high amount of heat produced by the Peltier module while the active cooling, to avoid the internal conduction of this heat a highly effective heat sink is to be provided. As weight and size are a key constrain into the project modelling forced air convection cooling heat sink is selected.

- Power source allocation:

The Peltier module and the forced air convection heat sink both required a power supply to operate, a battery is provided to fulfil this power demands. Li ion battery is selected as it light in weight and easily rechargeable by an external power source. A direct current Li ion battery is customized. The embedded closed loop system is also powered by the same unit.

- Programming logic:

The programming logic of the embedded system are operated on microcontroller as it an open source and can be easily integrated with various peripheral devices. The microcontroller is used to sense the temperature and variations into the beverage and accordingly adjust temperature. The microcontroller also handles the GUI of the model.

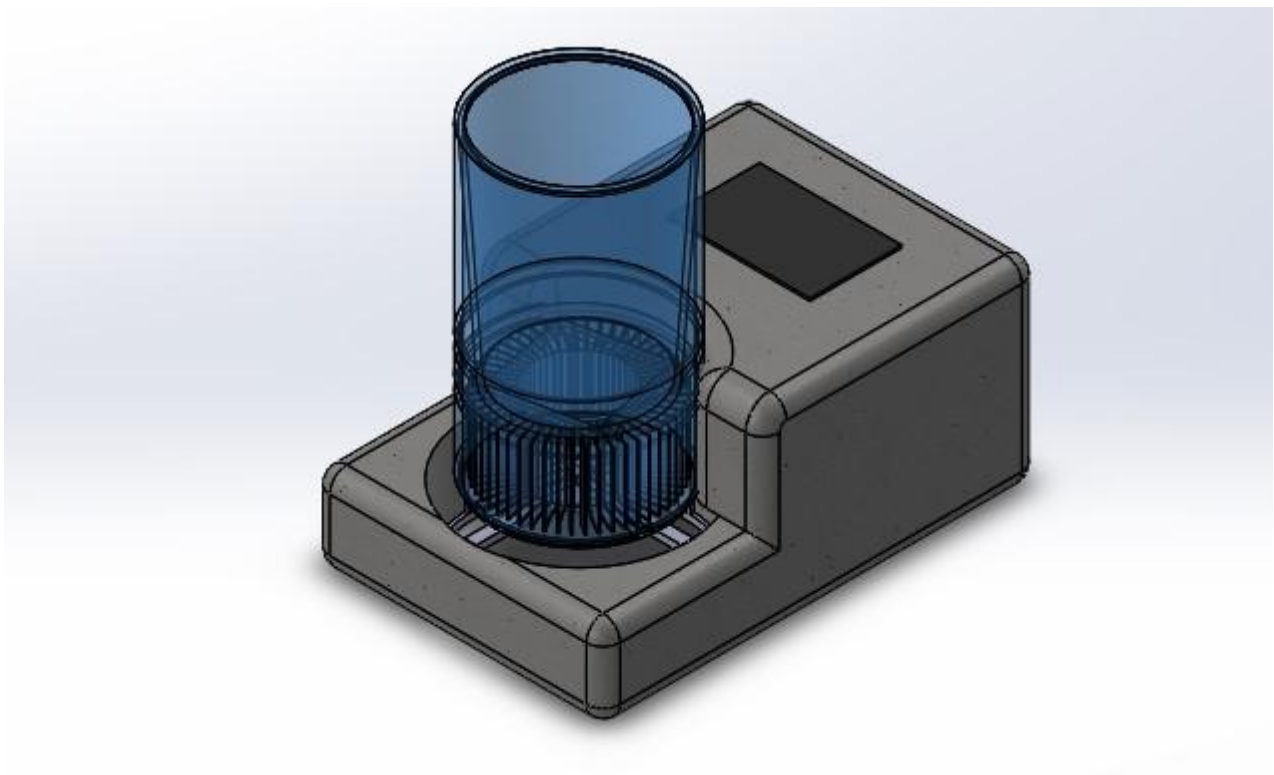

Figure: 2.2 Design of the Prototype

2.1 ADVANTAGES

- Instant Active Heating and Active Cooling of the Beverage
- Low power consumption

- Mobility

2.2 LIMITATIONS

- High initial cost.
- Size Constraint.

III. CONCLUSION

Different Peltier modules were tested during the process. Power supply is the main factor acting here so the battery was tested and verified by several experiments conducted. By combining all this equipment's a product can be made which will maintain the temperature range between 15°C to 50°C. This project aims to work in between this given range and produce efficient results on it.

REFERENCES

- [1] Adrian Soto, Alberto Berrueta, Pablo Sanchis, Alfredo Ursúa, "Analysis Of The Main Battery Characterization Techniques And Experimental Comparison Of Commercial 18650 Li-Ion Cells", Institute of Electrical and Electronics Engineers, 2019, pp. 1-6.
- [2] Mohammad Reza Saheri, Richard W. Bonner, "the use of Air-cooled heat sink which have light weight and high performance," Institute of Electrical and Electronics Engineers, 2018, pp. 224-227.
- [3] Rohit Gupta, Chayan Das, Ankit Roy, RanjanGanguly, AmitavaDatta, "Ardiuno Based Temperature And Humidity Control For Condensation On Wettability Engineered Surface," Institute of Electrical and Electronics Engineers, 2018, pp. 1-6.
- [4] Arjun Kumar G.B., Pruthviraj B.G., Chethan Kumar Y. K., "Design And Implementation Of Peltier Based Solar Powered Portable Refrigeration Unit," Institute of Electrical and Electronics Engineers, vol.2, 2017, pp. 1971-1974.16
- [5] PavanAttavane, Arjun G.B.,RajathRadhakrishna, "Solar Powered Portable Food Warmer And Cooler Based On Peltier Effect," Institute of Electrical and Electronics Engineers, vol.2, 2017, pp. 1975-1978.
- [6] NavdeepJakhar, NileshBaheti, Mahesh Chand Gurjar, Parag Sharma , "Model Development Of Refrigerator And Heater Based On Peltier Module And Fresnel Lens," Institute of Electrical and Electronics Engineers, 2016, pp. 23-25.
- [7] Saket Kumar, Ashutosh Gupta, Gaurav Yadav, Hemender Pal Sing, "Peltier Module For Refrigeration And Heating Using Embedded System," Institute of Electrical and Electronics Engineers, 2015, pp. 314-319.
- [8] Nandini K.K., Muralidhara, "Peltier Based Cabinet Cooling System Using Heat Pipe And Liquid Based Heat Sink," Institute of Electrical and Electronics Engineers, 2013, pp. 1-5.
- [9] Steve Harrington, "Optimal Heat Transfer For Liquid Cooling With Minimal Coolant Volume," Institute of Electrical and Electronics Engineers, 2011, pp. 43-47.
- [10] Takahiro Katoh, Marlin Vogel, ShlomoNovotny,Guoping XU, "New Attempt Of Forced- Air Cooling For High Heat-Flux Applications," Institute of Electrical and Electronics Engineers, vol.2, 2004, pp. 34-39.